

EN



# USER MANUAL

# WELCOME TO THE MR BEAM COMMUNITY

Finally, your **Mr Beam II dreamcut** stands before you, ready to help you with the implementation of your creativity!

In the last couple of years we have worked hard for this moment and put a lot of heart and soul into development and production.

With the hashtag [#madewithmrbeam](#), you will find inspiration from other members of the Mr Beam Community. Of course we would also be pleased if you share your creations on social media and tell your friends about them, too.

We are curious to know how you will use your Mr Beam and what you will create with it!

We are looking forward to your feedback, whether in pictures or text.

If something does not work out as expected, please do not hesitate to contact us:  
[www.mr-beam.org/ticket](http://www.mr-beam.org/ticket)

Have fun with your Mr Beam!

The entire Mr Beam Team





# TABLE OF CONTENT

## 01 WELCOME

Using this User Manual.....	2
Mr Beam.....	3

## 02 SAFETY & CONFORMITY

Precautionary Measures .....	6
Safety Precautions when Operating Mr Beam.....	8
Laser Safety.....	10
Warnings and Instruction Signs.....	11
Intended Use .....	14
EU Declaration of Conformity (german) .....	15

## 03 COMPONENTS OVERVIEW

Scope of Mr Beam Delivery with Air Filter System.....	18
Scope of Mr Beam Delivery without Air Filter System .....	19
Overview Mr Beam .....	20
Connections.....	21
Button .....	22
Camera .....	23
Status Light Meanings .....	24

## 04 SETUP PROCEDURE

Positioning.....	28
Unpacking.....	29
Laser Head Connection.....	30
Suction/Air Filter System Connection.....	32
Suction/Air Filter System.....	33
Powering on.....	34
Powering off .....	35

# TABLE OF CONTENT

Connecting to a Computer/Tablet.....	36
Option 1 Connection via Router.....	37
Option 2 Direct Connection .....	42

## 05 SOFTWARE MR BEAM LASERBENCH

Mr Beam Laserbench.....	46
Software Update.....	49

## 06 WORKING WITH YOUR MR BEAM

Focusing .....	52
Materials & Size of Workpiece .....	54

## 07 MAINTENANCE & CARE

Regular Maintenance & Care .....	58
Cleaning Laser Head.....	59
General Cleansing.....	68
Filter Change.....	70
Repairs .....	72

## 08 ADDITIONAL INFORMATION

Technical Data.....	76
Storage & Transport/Support .....	77
Disposal.....	78

## 09 GENERAL TERMS AND CONDITIONS

General Terms and Conditions .....	82
Contact Addresses .....	83



# Chapter 01

# W E L C O M E

---

We are delighted that you have opted for a Mr Beam!  
Please read this manual completely, even though you  
may already be familiar with some functions.

# USING THIS USER MANUAL

*Warning:* These operating instructions must be carefully read and observed before using Mr Beam for the first time. Non-observance of individually listed points in the instructions manual can cause personal injury and/or property damage!

No part of this manual may be reproduced, edited or otherwise modified in any form without the prior written consent of Mr Beam Lasers GmbH. The rights for reproduction in any form, in particular in electronic, print and other media, are reserved. Mr Beam Lasers GmbH reserves the right to change specifications of the hardware and software described in these user manual at any time and without prior notice.

The following symbols are used to facilitate the understanding of this user manual:



*Warning:* This area represents a special danger for the user or the person responsible for maintenance if the operating instructions are not observed.



*Warning:* In these areas, pay particular attention to the possible dangers of laser light.

Additional accessories must be compatible with the base unit (if you have any questions, please contact Mr Beam Support: [www.mr-beam.org/ticket](http://www.mr-beam.org/ticket)).

Please make sure you have the latest version of the Mr Beam user manual.

The latest version of the user manual can be found at: [www.mr-beam.org/en/downloads/](http://www.mr-beam.org/en/downloads/)

If your language is not included in the user manual, you can download it from [www.mr-beam.org/en/downloads/](http://www.mr-beam.org/en/downloads/)

If you have any questions, please contact Mr Beam Support: [www.mr-beam.org/ticket](http://www.mr-beam.org/ticket)

Please keep this user manual for future reference.

This user manual is a translation from the original user manual in german. Mr Beam Lasers GmbH assumes no warranty for translation errors.

Date of this manual: 01 November 2019



# MR BEAM

Your Mr Beam is designed for contactless cutting and engraving of various materials. With the help of laser light, heat is generated selectively to evaporate, melt or burn materials. This thermal process can be used to make cuts and engravings on flat materials. Due to its high precision, the process is suitable for cutting out complex shapes and engraving delicate designs.

The user can connect to Mr Beam with a computer or tablet via router or directly via WiFi. Except for the browser Google Chrome, no additional software is required to operate Mr Beam. Mr Beam is already equipped with all necessary software and is operated by the user via the web interface Mr Beam Laserbench.

After files in common file formats have been loaded into the Design Library, the user can select predefined settings for the material. The laser process is prepared by the computer or tablet and started by additionally pressing the button. A camera allows a preview of the work surface, which makes an exact placement of the design on the workpiece possible.

## **Manufacturer**

Mr Beam Lasers GmbH  
Gollierstr. 70  
80339 Munich  
Germany



# SAFETY & CONFORMITY

---

Please note that this chapter is particularly important. Your Mr Beam can only work safely if you pay attention to all aspects of it. It is therefore essential that you read and understand this chapter before operating your Mr Beam !

# PRECAUTIONARY MEASURES

## **Safety-conscious working with Mr Beam**

The entire user manual, in particular Chapter 2 „Security & Conformity“, must be read and understood by any person performing the installation, commissioning, use, maintenance and/or repair of Mr Beam.

If several persons work with Mr Beam, the proprietor or, if appropriate, the owner or another person responsible for access to the device, has the responsibility to ensure that all users are familiar with the safety regulations of the device.

Minors are only allowed to use Mr Beam under adult supervision.

The device must be switched off and disconnected from the main power supply for all work relating to installation, commissioning, equipping, changes in operating conditions and modes of operation, maintenance, inspection and repair.

The operation of Mr Beam is only permitted with equipment and spare parts included in the delivery and/or released by Mr Beam Lasers GmbH.

# PRECAUTIONARY MEASURES

All safety instructions listed below must be followed by each user:

- Any way of working that compromises the safety of Mr Beam should be avoided.
- The user is obliged to exclude the commissioning of Mr Beam by unauthorized persons (e.g. by operating devices against unauthorized use and/or by removing the key)
- The socket must be easily accessible and in the immediate vicinity of the device. In an emergency, the main plug and the key must be disconnected immediately.
- The user must ensure that Mr Beam is only operated under perfect conditions.
- Before commencing each use, the user is obliged to check Mr Beam for externally recognizable defects, damages or irregularities. Detected changes, even unusual operating behavior, must be remedied without delay. The use of Mr Beam should be discontinued until the defect has been completely remedied.
- Cleanliness and clarity at and around the workplace of Mr Beam must be ensured.
- During the laser process, the processed material is vaporized by Mr Beam. The operation therefore causes fire odors and vapors. Please make sure that Mr Beam is operated exclusively with the appropriate suction/filter system.
- Shutting down and/or dismantling of safety devices is prohibited at all times. This can for instance lead to severe burns and/or loss of sight.
- The work listed below must only be carried out by trained personnel when the device is switched off and with the mains plug disconnected: Set-up, retrofitting, maintenance and inspection activities.
- If the disassembly of safety devices is necessary for repair/maintenance work, it is the responsibility of the person carrying out the work to reassemble them immediately and before the next commissioning, and to check for proper functioning.
- For safety reasons, any remodeling, modification or alteration of Mr Beam is prohibited under any circumstances.

# SAFETY PRECAUTIONS WHEN OPERATING MR BEAM

## **Opening the lid during a laser job**

When the protective cover is lifted or opened, the power supply to the laser is interrupted immediately. Opening the lid during a laser job can lead to an incomplete work result, such as an incomplete engraving. If possible, we recommend not to interrupt a laser job.

Since vapors can escape when the lid is opened during a laser job, first press the button to activate pause mode. Then wait briefly until the suction system has removed all vapors. You can now open and close the protective cover to continue the operation by pressing the button again.

## **The following safety precautions must be taken before each use of Mr Beam:**

Combustible materials can be ignited by the laser light. Therefore, all workpiece residues must be removed after each operation. The interior and immediate surroundings of Mr Beam may not be used as a store for flammable materials. A fire extinguisher and fire blanket must be available in the vicinity of the device at all times.

The user must be present when performing laser jobs!

Generally, only materials that have been approved for processing by Mr Beam Lasers GmbH via the link [www.mr-beam.org/en/materials/](http://www.mr-beam.org/en/materials/) may be used.

Before putting the device into operation, the user must clarify whether harmful substances can be produced by the processing of materials which could damage Mr Beam itself, the Air Filter System, the environment and/or persons. If the Mr Beam Air Filter System cannot filter out harmful substances, you should not use these materials. It is therefore the responsibility of the user to comply with national and regional limits for dust, smoke and gases. For this, we recommend Mr Beam Air Filter System.

Commissioning of Mr Beam is only permitted with an appropriate suction system (see Chapter 4 „Setup procedure“). For information on how and at what intervals to change the filter, please refer to Chapter 7 „Maintenance and Care“.

The key is a convenient way to grant access to Mr Beam only to authorized users.

# SAFETY PRECAUTIONS WHEN OPERATING MR BEAM



*Warning:* The processing of conductive materials (e.g. carbon fibers) releases dust particles and smoke, which can lead to lasting damage to components and/or electronics (e.g. short circuits). Processing conductive materials will void the warranty.

Materials containing chlorine, such as PVC, release corrosive vapors during processing, which can damage components. The use of such materials, will result in the exclusion of the warranty.

If you have any questions before starting work, please do not hesitate to contact Mr Beam Support: [www.mr-beam.org/ticket](http://www.mr-beam.org/ticket)

Many metals, especially uncoated aluminium, copper, silver and gold, must not be processed with the laser due to low absorption, as these materials lead to high reflections of the laser light. These metals and/or other reflective materials must under no circumstances be brought into the beam path of the laser, as a directional reflection can damage and/or destroy the protective cover.

*Warning:* The engraving of a commercially available mirror may only be done on the uncoated back.



The laser optics are adjusted before delivery and may only be carried out by trained personnel with measuring equipment. Improper adjustment may result in uncontrolled laser light emission and may impair and/or destroy the correct operation of Mr Beam.

# LASER SAFETY

To assess the potential hazards of laser systems, they are divided into eight safety classes: 1, 1C, 1M, 2, 2M, 3R, 3B and 4. Mr Beam is a class 1 laser. This is guaranteed by its enclosed protective housing and its safety devices.

In this protective housing, your Mr Beam works with a laser source that emits an intense and visible laser light. The accessible laser light is very dangerous to the eye (complete loss of eye sight) and very dangerous to the skin (risk of burning). Diffused light can also be dangerous. There is a risk of fire when using this laser light. Without protective devices, this direct light or diffused reflected light is dangerous to both persons and objects! Please note that improper commissioning of the device will invalidate the status of Class 1 safety, and may result in the release of harmful light. The following risks may result from using laser lights without protective measures:

- Eyes: retinal burns, complete loss of sight
- Skin: burns
- Clothing: fire hazard

The laser may only be operated under the conditions specified by Mr Beam.

Never modify or disassemble your Mr Beam and its laser/laser unit. Do not operate any device that has been modified or dismantled!

Service technicians who have to bridge the safety circuit (interlock) for maintenance or repair tasks are obliged to wear standard-compliant protective clothing for laser light (wavelength 450 nm, 5 W). The bridging must be reassembled and checked for proper functioning before the next commissioning.



# WARNINGS AND INSTRUCTION SIGNS

All warning and information signs attached to your Mr Beam are located in places that may be a source of danger before and/or during operation. Damaged or lost warning and information signs must be replaced immediately. The missing warning and information signs can be ordered via Mr Beam Support ([www.mr-beam.org/ticket](http://www.mr-beam.org/ticket)) or replicated using the templates on the following page.

## On the device:

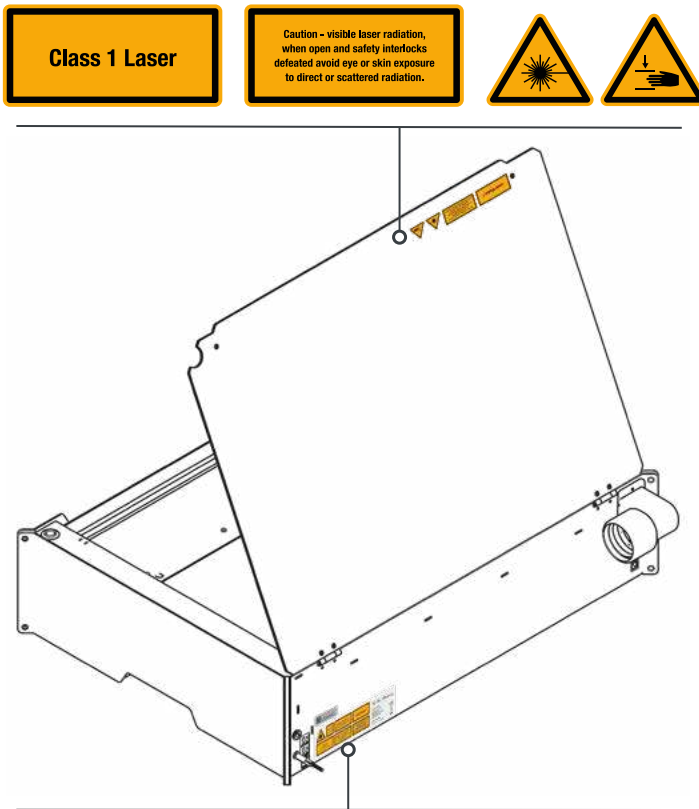

## On the laser head:

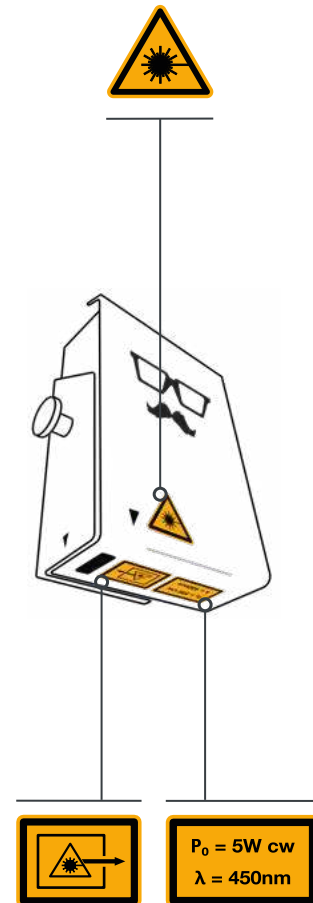

Year of production: 20XX  
Name: MrBeam-XXXX  
S/N: 000000XXXXXXXXXX-ZX

$P_0 = 5W \text{ cw}$   
 $\lambda = 450nm$

Switch off device and remove power plug before any cleaning or maintenance.

**Class 1 Laser**

Model: Mr Beam  
Made in Germany

Mr Beam Lasers USA Inc.  
2220 Northmont Pkwy  
Suite 250  
Duluth, GA 30096-5835  
[www.mr-beam.org](http://www.mr-beam.org)  
Input: 19V  $\approx$  3.42A

This device incorporates a RF module. The RF module is already certified under the FCC ID: 2ABCB-RP132 and IC ID: 20953-RP132.

Maintenance and inspection activities are only to be conducted by trained personnel and the device must be switched off.

Caution - visible laser radiation, when open and safety interlocks defeated avoid eye or skin exposure to direct or scattered radiation.

Mr Beam incorporates a RF module. The RF module is already certified under the FCC ID: 2ABCB-RP132 and IC ID: 20953-RP132.

# WARNINGS AND INSTRUCTION SIGNS

The templates for the replication of the warning and information signs can be found on this page.

Print this page in DIN A4 format so that the warning and information signs correspond to their original size.

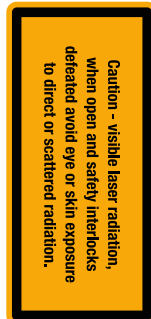

	$P_0 = 5W$ CW $\lambda = 450nm$
Maintenance and inspection activities are only to be conducted by trained personnel and the device must be switched off.	Switch off device and remove power plug before any cleaning or maintenance.
Caution - visible laser radiation, when open and safety interlocks defeated avoid eye or skin exposure to direct or scattered radiation.	<b>Class 1 Laser</b>

**Model:** Mr Beam  
**Made in:** Germany  
**Mr. Beam Lasers USA Inc.**  
 2220 Northmont Pkwy  
 Suite 250  
 Duluth, GA 30096-5835  
[www.mr-beam.org](http://www.mr-beam.org)  
**Input:** 19V  $\approx$  3.42A

This device incorporates a RF module. The RF module is already certified under the FCC ID: 2ABCB-RP132 and IC ID: 20953-RP132.



# INTENDED USE

Your Mr Beam was developed for contactless cutting and engraving of various materials. These includes wood, acrylic, cardboard, paper, leather, selected plastics, anodized aluminum, etc.

For a list of approved and tested materials and thicknesses, please visit: [www.mr-beam.org/en/materials/](http://www.mr-beam.org/en/materials/)

For safety reasons, only materials approved by Mr Beam Lasers GmbH are approved for processing in your Mr Beam.

Operation is only permitted if Mr Beam is in perfect condition (also see Chapter 2 „Safety & Conformity“).

The manufacturer accepts no liability for any personal injury and/or damage to property resulting from the inappropriate or improper use of Mr Beam. Repair, maintenance or opening of Mr Beam may only be performed by persons who are familiar with the intended area of application and the dangers of Mr Beam, and who must have received appropriate training. Failure to observe the operating, maintenance and repair instructions set out in this manual excludes Mr Beam Lasers GmbH from any liability.

*Warning:* The processing of conductive materials (e.g. carbon fibers) releases dust particles and smoke, which can lead to lasting damage to components and/or electronics (e.g. short circuits). Processing of conductive materials will void the warranty.

Materials containing chlorine, such as PVC, release corrosive vapors during processing, which can damage components. The use of such materials, will result in the exclusion of the warranty.

If you have any questions, please do not hesitate to contact Mr Beam Support: [www.mr-beam.org/ticket](http://www.mr-beam.org/ticket)

The technical data for the operator according to OStrV („Arbeitsschutzverordnung zu künstlicher optischer Strahlung“ [german]) and EG/2006/25 can be found in the technical data.



# EU DECLARATION OF CONFORMITY (GERMAN)

## EU Konformitätserklärung EU Declaration of Conformity



*Mr. Beam*

Firma / Company: Mr Beam Lasers GmbH  
 Adresse / Address: Gollnerstrasse 70  
 80339 München  
 Produktkategorie / Product: Maschine  
 Modellbezeichnung / Model name: Lasercutter  
 Hersteller / Manufacturer: Mr Beam Lasers GmbH  
 Artikelnummer / Article number: ---  
 Seriennummer / Serial number: 000000012345678-2E (Beispiel)

**Das Produkt erfüllt die einschlägigen Harmonisierungsrechtsvorschriften der Union:**  
**The product fulfill the relevant European harmonisation legislations:**

Rechtsvorschrift / legislation:	Titel / Title:
2014/53/EU	Funkrichtlinie / Radio Equipment Directive (ABl. L 153, 22.5.2014, p. 62-106)
2006/42/EC	Maschinenrichtlinie / Machinery Directive (ABl. L 157, 9.6.2006, p. 24-86)
2011/65/EU:2014-02-14	RoHS (ABl. L 174, 1.7.2011, p. 88-110)

**Die Übereinstimmung mit den Anforderungen der europäischen Harmonisierungsrechtsvorschriften wurde durch die Anwendung der folgenden harmonisierten Normen und technischen Spezifikationen nachgewiesen:**

**The compliance with the requirements of the European harmonisation legislations was proved by the application of the following harmonised standards and technical specifications:**

Normen / Standards:	Beschreibung	Description
EN 60825-1:2014-08	Sicherheit von Lasereinrichtungen Teil 1: Klassifizierung von Anlagen und Anforderungen	Safety of laser products – Part 1: Equipment classification and requirements
EN 60825-4:2011-12	Sicherheit von Lasereinrichtungen Teil 4: Laserschutzwände	Safety of laser products – Part 4: Laser guards
EN 11553-3:2008	Sicherheit von Maschinen - Laserbearbeitungsmaschinen - Teil 1: Allgemeine Sicherheitsanforderungen	Safety of machinery - Laser processing machines - Part 1: General safety requirements
EN 11553-3:2013	Sicherheit von Maschinen - Laserbearbeitungs-maschinen - Teil 3: Lärminderungs- und Geräuschmessverfahren für Laserbearbeitungs-maschinen und handgeführte Laserbearbeitungs-geräte sowie zugehörige Hilfseinrichtungen (Genauigkeitsklasse 2)	Safety of machinery - Laser processing machines - Part 3: Noise reduction and noise measurement methods for laser processing machines and hand- held processing devices and associated auxiliary equipment (accuracy grade 2)
EN 12100:2011-03	Sicherheit von Maschinen - Allgemeine Gestaltungsleitsätze - Risikobeurteilung und Risikominderung	Safety of machinery - General principles for design - Risk assessment and risk reduction
EN 11252:2014-02	Lasers und Laseranlagen - Lasergerät - Mindestanforderungen an die Dokumentation	Lasers and laser-related equipment - Laser device - Minimum requirements for documentation
EN 55032:2012-12 Class B	Elektromagnetische Verträglichkeit von Multimedia-geräten und -einrichtungen - Anforderungen an die Störaussendung	Electromagnetic compatibility of multimedia equipment - Emission requirements
EN 55024:2010 + A1:2015	Einrichtungen der Informationstechnik - Störfestigkeitseigenschaften - Grenzwerte und Prüfverfahren	Information technology equipment - Immunity characteristics - Limits and methods of measurement
EN 61000-3-2:2014-08	Elektromagnetische Verträglichkeit (EMV) - Teil 3-2: Grenzwerte - Grenzwerte für Oberschwingungs-ströme (Geräte- Eingangstrom <= 16 A je Leiter)	Electromagnetic compatibility (EMC) - Part 3-2: Limits - Limits for harmonic current emissions (equipment input current <= 16 A per phase)
EN 61000-3-3:2013-08	Elektromagnetische Verträglichkeit (EMV) - Teil 3-3: Grenzwerte - Begrenzung von Spannungs-schwankungen und Flicker in öffentlichen Niederspannungs- Versorgungsnetzen für Geräte mit einem Bemessungsstrom <= 16 A je Leiter, die keiner Sonderanschlussbedingung unterliegen	Electromagnetic compatibility (EMC) - Part 3-3: Limits - Limitation of voltage changes, voltage fluctuations and flicker in public low-voltage supply systems, for equipment with rated current <= 16 A per phase and not subject to conditional connection
EN 61000-6-1:2007-01	Elektromagnetische Verträglichkeit (EMV) - Teil 6-1: Fachgrundnormen - Störfestigkeit für Wohnbereich, Geschäfts- und Gewerbereiche sowie Kleinbetriebe	Electromagnetic compatibility (EMC) - Part 6-1: Generic standards - Immunity for residential, commercial and light-industrial environments
EN 61000-6-3:2011-09	Elektromagnetische Verträglichkeit (EMV) - Teil 6-3: Fachgrundnormen - Störaussendung für Wohnbereich, Geschäfts- und Gewerbereiche sowie Kleinbetriebe	Electromagnetic compatibility (EMC) - Part 6-3: Generic standards - Emission standard for residential, commercial and light-industrial environments
EN 50581:2012	Technische Dokumentation zur Beurteilung von Elektro- und Elektronikgeräten hinsichtlich der Beschränkung gefährlicher Stoffe	Technical documentation for the assessment of electrical and electronic products with respect to the restriction of hazardous substances

Weitere Informationen / additional information:  
keine / none

München / 03.05.2019  
Place / Date

*Teja Philipp*  
Managing Director  
Teja Philipp

*R. Kaindl*  
CE Consulting / Dokumentenverantwortlicher  
Roland Kaindl (TKRM UG haftungsbeschränkt)

This copy of the declaration of conformity is from 03.05.2019.

The latest version of the declaration of conformity can be found in the latest version of the user manual. This can be downloaded from: [www.mr-beam.org/en/downloads/](http://www.mr-beam.org/en/downloads/)



# COMPONENTS OVERVIEW

---

The following chapter gives you an overview of the various components and connections of your Mr Beam.

# SCOPE OF MR BEAM DELIVERY WITH AIR FILTER SYSTEM

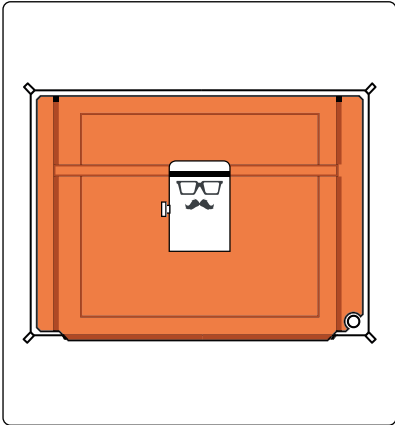

Laser head  
Mr Beam

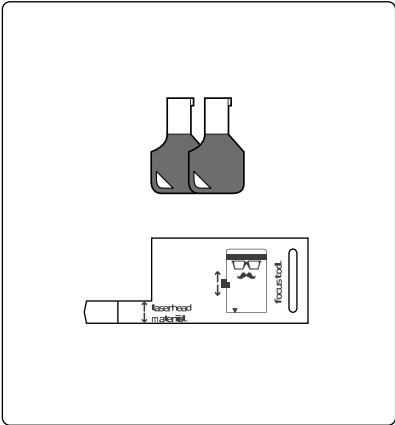

2 keys  
Focus Tool

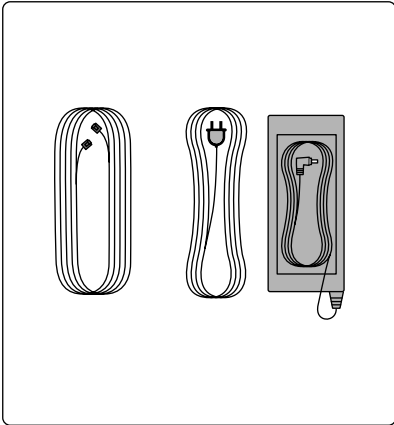

Cable Mr Beam Air Filter System  
Power cable  
Power supply

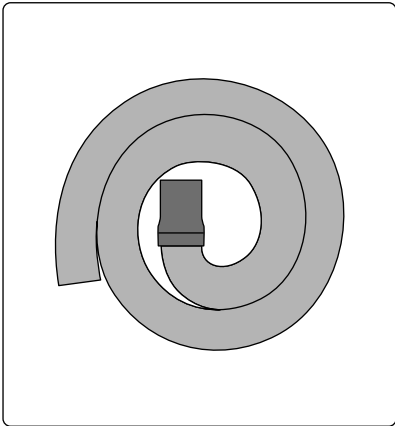

Ventilation hose

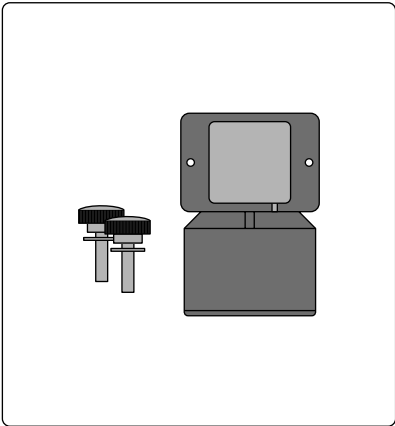

2 screws  
2 washer  
Suction socket

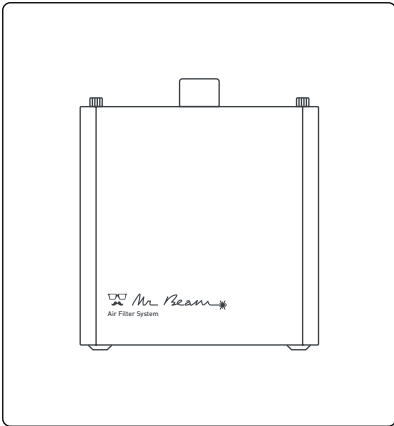

Mr Beam Air Filter System



# SCOPE OF MR BEAM DELIVERY WITHOUT AIR FILTER SYSTEM

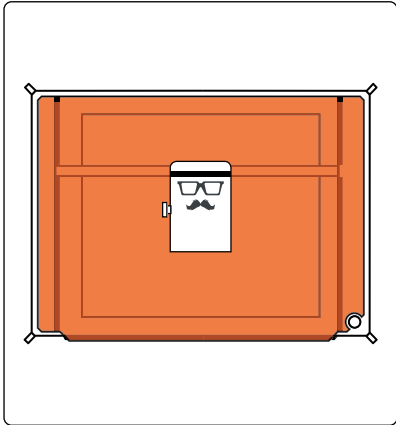

Laser head  
Mr Beam

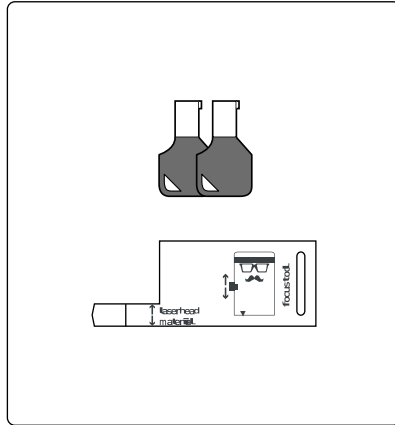

2 keys  
Focus Tool

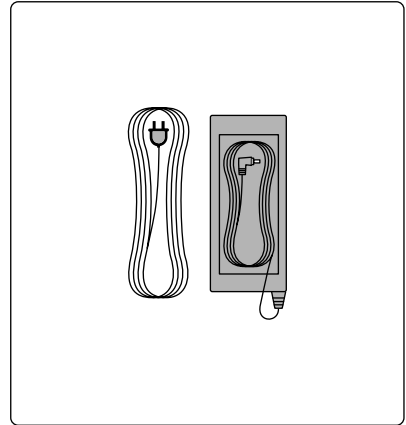

Power cable  
Power supply

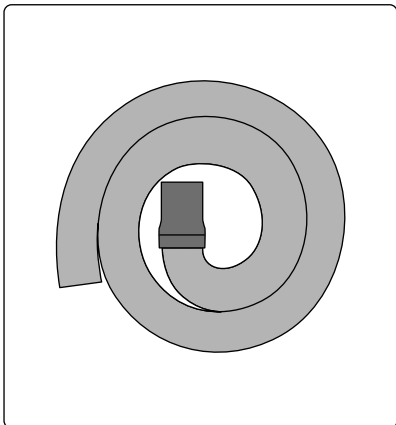

Ventilation hose

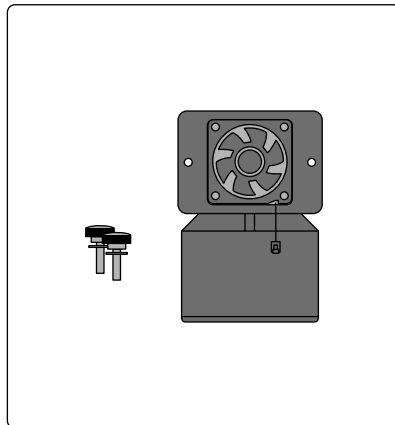

2 screws  
2 washer  
Suction socket with fan



For indoor use we recommend a **Mr Beam Air Filter System**. If you don't have one yet, order it now from our shop at [store.mr-beam.org](https://store.mr-beam.org)



# OVERVIEW MR BEAM

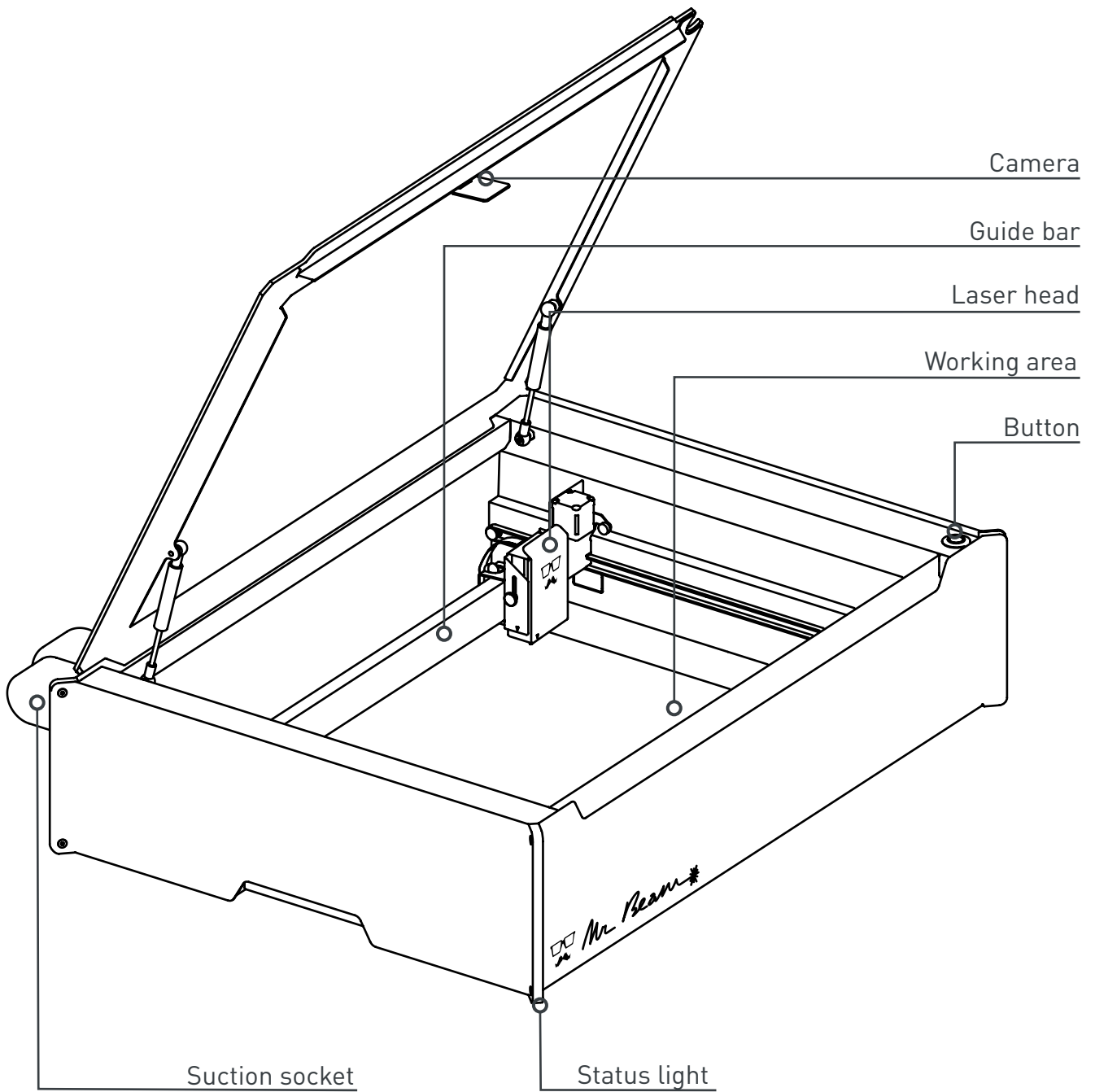

# CONNECTIONS

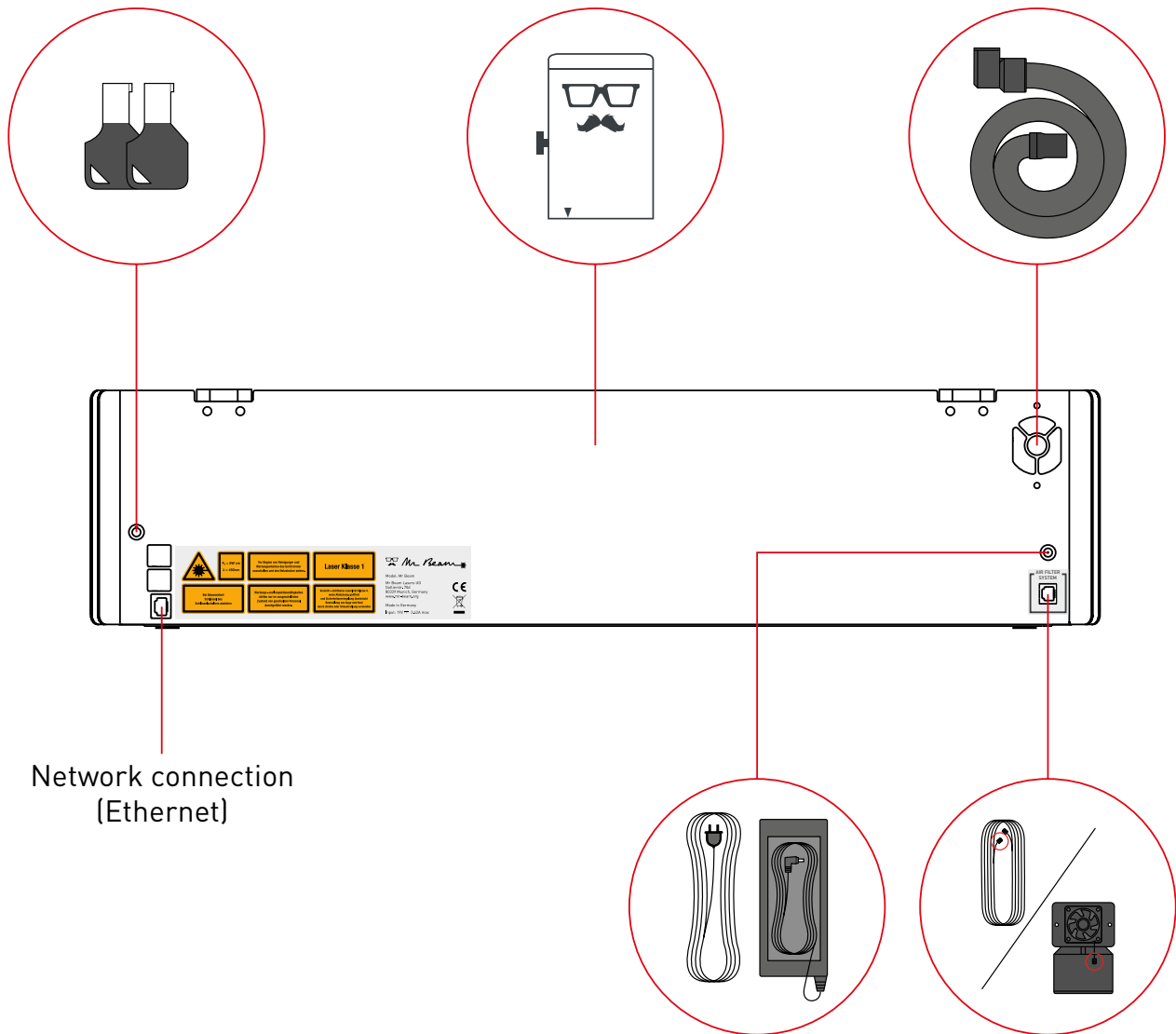

# BUTTON

The button is a push button on the top of Mr Beam. It is assigned several functions, which are explained below.

*Note:* The status light also lights up in the shut down state.

## **Turning on**

After the key is inserted into the key switch and turned clockwise, briefly press the button. The light of the laser head is switched on immediately and after 10 seconds the Status Lights are also switched on.

## **Start a laser operation**

After you have prepared a laser job on Mr Beam Laserbench (the Mr Beam software), you can start the job on your Mr Beam by pressing the button once.

## **Pausing**

To pause a laser job, press the button, then wait briefly until the suction system has removed vapors. Now you can open and close the protective cover and continue the laser job by pressing the button again.

## **Shutting down**

Press and hold the button for five seconds to shut down your Mr Beam in an orderly manner. Your Mr Beam will shut down after about 15 seconds. Shutting down will not turn off your Mr Beam. To turn off, turn the key switch counterclockwise and remove it (see chapter 4 „Setup procedure“).

# CAMERA

In the lid of your Mr Beam is a camera, which supports you in positioning the design on the workpiece.

As soon as the lid is completely open, the camera automatically takes an image of the working area and the workpiece lying on it. This is then displayed on the Mr Beam Laserbench with a few seconds delay.

The image taken by the camera shows the workpiece on the working area, i.e. you can virtually place the selected design directly on the workpiece for subsequent processing. For an optimal image and precise positioning, you must ensure sufficient and uniform illumination of the working area.

The four magenta-coloured, round markers are relevant for precise positioning. If they do come off, please contact Mr Beam Support:

[www.mr-beam.org/ticket](http://www.mr-beam.org/ticket)

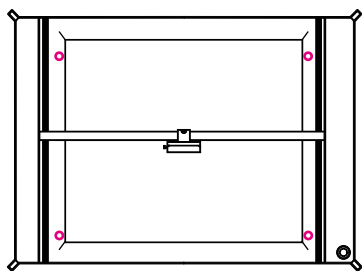

*Note:* After sticking in the markers, a calibration of the camera (Adjustment -> Camera Calibration) is necessary.

For exact positioning, the placement of the workpiece must be adjusted by moving the laser head.

The triangles on the laser head provide a reference for the exact exit of the laser light.

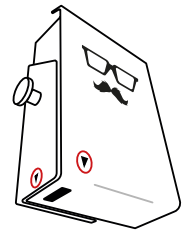

## Using the Camera

In summary, the following guidelines must be followed for the correct utilization of the camera:

1. Open the lid to the highest position.
2. Position the workpiece in the working area.
3. Wait a few seconds for the image to transfer to your computer/tablet. If the image is not optimal, please wait a few seconds again until the camera has captured and transferred another image.
4. Close the lid and proceed with further settings and work steps as required.

Live tracking of the laser is not possible. The images are only saved for editing and are then automatically deleted.

# STATUS LIGHT MEANINGS

The status light indicates different operating states of Mr Beam.

*Note:* The signals listed here are in beta stage and can change with software updates.

Breathing orange	Gain access to your Mr Beam via <a href="http://find.mr-beam.org">find.mr-beam.org</a>
Breathing green	Gain access to your Mr Beam via WiFi Access Point
Breathing white	Gain access to your Mr Beam via common addresses/hostnames in your network
White on blue dripping	Preparation laser job
Blue flashes	Waiting for laser confirmation by pressing the button
Blue trickling on white	Implementation of laser job <i>Note:</i> The larger the white part, the more advanced the laser job.
Blue pulsating at the top, white at the bottom	Pause
Orange	Laser job completed <i>Note:</i> It is recommended that you wait for the suction.
Green	Laser job completed, lid can be opened.
Red flashes	Button is held for shutdown
Fast red flashes	Error
Red	Shutting down
Red/white flashes	Button pressed, no resulting action







# SETUP PROCEDURE

---

Your Mr Beam is now ready for first use!

In the following chapter we will guide you from unpacking to setting up a network connection.

While setting up your Mr Beam, remember, that it was assembled and packaged with great care by us. Please take time to unpack and set it up just as carefully.

# POSITIONING

Please note the following positioning guidelines before setting up your Mr Beam:

- Working temperature between 0°C and 25°C (32°F and 77°F)
- No high temperature fluctuations
- Use only in closed rooms, contact with moisture must be avoided
- Humidity between 30% and 60% with no condensation
- Dust-free environment
- No strong exposure to sunlight (sun protection measures)
- No mechanical shocks
- Sufficient air circulation
- Flat/horizontal work surface
- A save stand of the device must be ensured
- Own work table to avoid vibration from other machines and work processes
- Socket should be easily accessible and in the immediate vicinity of the device, in an emergency power plug and key must be deductible
- The power circuit of the socket must be sufficiently protected.
- Fire extinguisher and fire blanket in the immediate vicinity

# UNPACKING

## 1. Opening the box

Place the carton on a flat surface. To open the box please do not use sharp objects that can damage the protective cover. Then pull out the inner box with the laser head and put it aside.

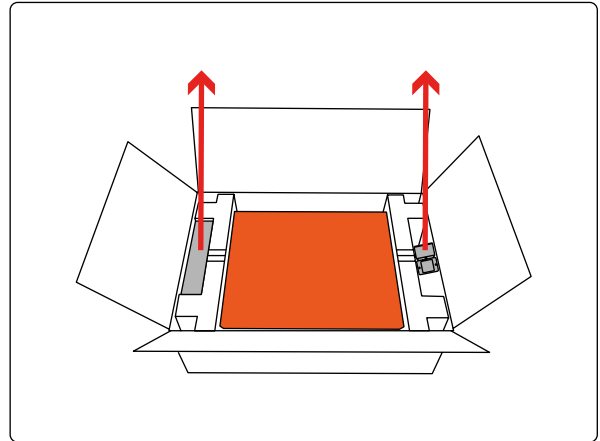

## 2. Removal from carton

Take Mr Beam out of the carton and remove the transport protection on both sides

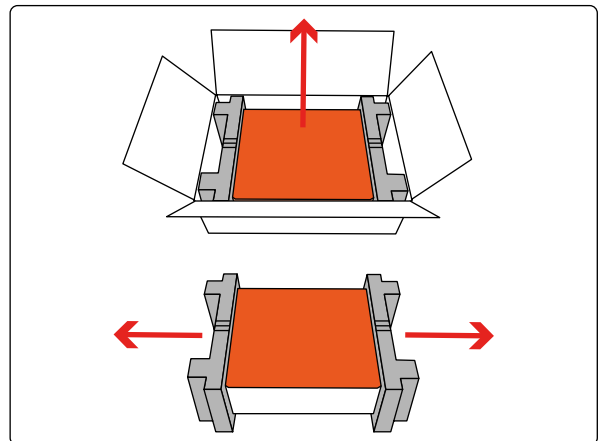

## 3. Removing the transport lock

Remove the transport lock inside the device.

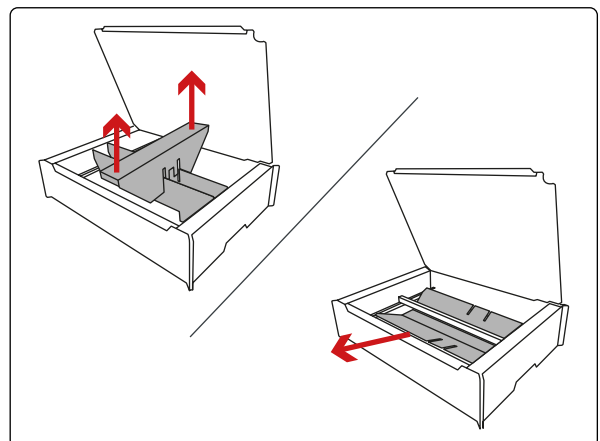

# LASER HEAD CONNECTION

## 1. Mount the laser head

The laser head can be mounted at different heights, see Chapter 6 „Working with your Mr Beam“.

First, mount the laser head in any position at the bottom. Then slightly compress the carriage and engage the laser head at the top.

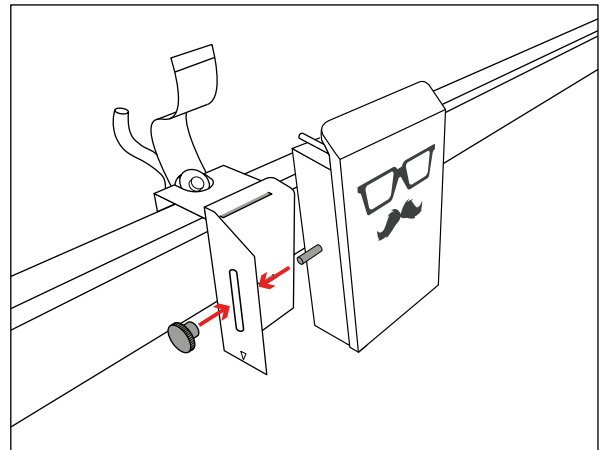

## 2. Insert the ribbon cable

Now insert the ribbon cable into the socket on the back of the laser head. If necessary, extend the black bar beforehand. Finally insert the hose as well (only in the “dreamcut” modell).



*Warning:* The ribbon cable may only be connected and disconnected if Mr Beam is shut down and turned off! Failure to do so will result in the inoperability of Mr Beam!

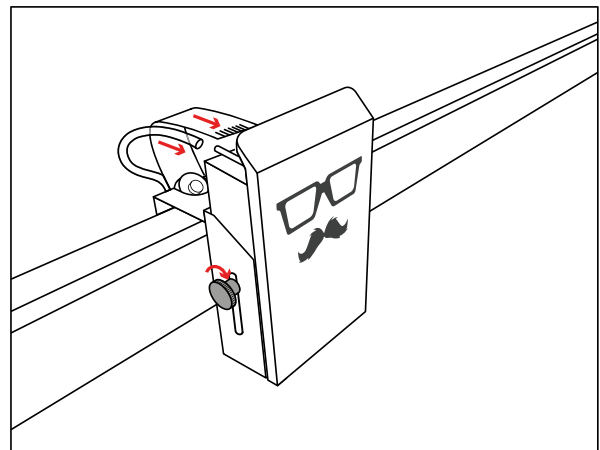

## 3. Lock the bracket

Then lock the cable with the bracket.

To remove the cable, first loosen the black bracket again.

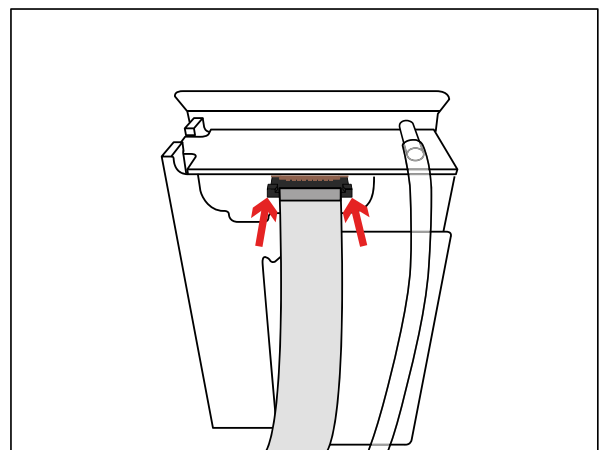

**Detailed explanation**

An explanation with video on the topics „Unpacking“, „Laser Head Connection“ and „Suction/Air Filter System Connection“ can be found online at:

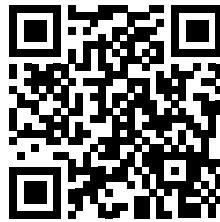

<https://youtu.be/rnfK0t0U5hA>

# SUCTION/AIR FILTER SYSTEM CONNECTION

## 1. Suction socket connection

Connect the suction socket to the free end of the ventilation hose.

*Note:* The ventilation hose is fitted with a left-hand thread.

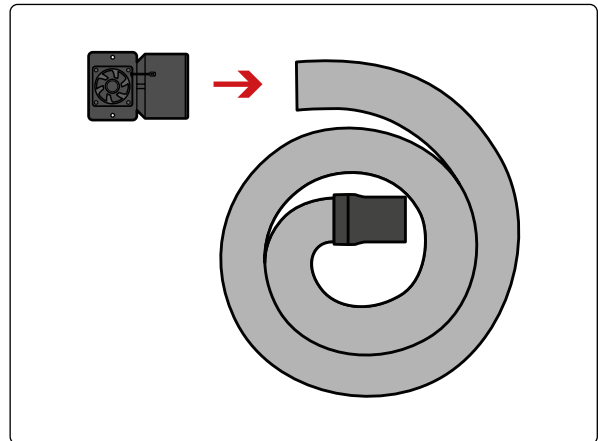

## 2. Connect to Mr Beam

Attach the suction socket to your Mr Beam using the two screws and washers provided. Then connect the ventilation hose to your Mr Beam.

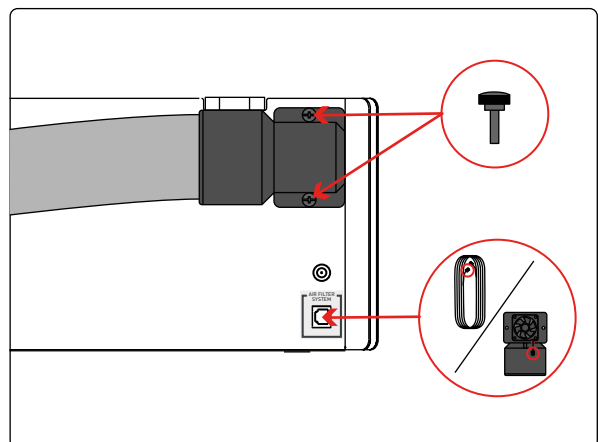

## 3. Exhaust ventilation

If you have a Mr Beam without Air Filter, make sure that the ventilation hose is fixed and the exhaust air can be discharged from the working area.

If you have a Mr Beam with an Air Filter System, connect the ventilation hose to the Air Filter System. Then connect the cable of the Air Filter System to your Mr Beam.

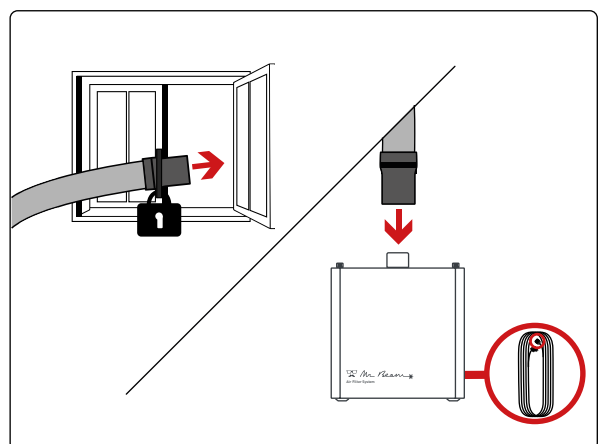

# SUCTION/AIR FILTER SYSTEM



*Warning:* Your Mr Beam must be connected to a working suction each time it is used, as processed materials are vaporized by Mr Beam during laser operations. Burn odors and vapors are therefore produced during operation. Please make sure that Mr Beam is operated exclusively with the appropriate suction.

In the following, the suction is described with two versions, the Suction System and the Mr Beam Air Filter System. The suction performance of both versions are controlled according to the presence of exhaust gases. If a lot of exhaust gases are produced during the machining process, for example when engraving wood, the suction performance is increased. This is associated with a higher or fluctuating noise level from the corresponding suction system. The smoke concentration is determined with an optical sensor. In the event of a sensor error, the suction capacity is increased to maximum for safety reasons. Note that it is the responsibility of the user to take the national and regional threshold values for dust, smoke and gases into account when selecting a filter and suction system.

## **Suction System (without Air Filter)**

The Suction System must not be used in enclosed rooms. The exhaust air must be able to be extracted from the working area at any time (e.g. outdoors).

*Warning:* The end of the hose must be fixed there so that no exhaust air can enter the operations room. It is important to ensure that the hose outlet is led far enough outdoors to prevent the exhaust gases from returning to the interior. If smoke accumulates in the device or strong smells develop, the process must be stopped immediately and the suction system checked.

The user must take into account the national and regional threshold values for dust, smoke and gases.



## **Mr Beam Air Filter System (with Air Filter)**

The Mr Beam Air Filter System allows you to operate your Mr Beam indoors in confined spaces without venting outside. This ensures that no unfiltered exhaust air escapes from your Mr Beam and that the user is not endangered at any time.

It is necessary to change the Air Filter of the Mr Beam Air Filter System regularly, depending on the degree of soiling.

The Air Filter System must stand on a flat ground and must not be covered.

# POWERING ON

## 1. Plug in the power cable

To avoid static charges that could destroy your computer and/or Mr Beam, please connect the AC adapter to your Mr Beam before plugging in the AC adapter into a socket (100-240V ~, 1.5A 50- 60Hz).

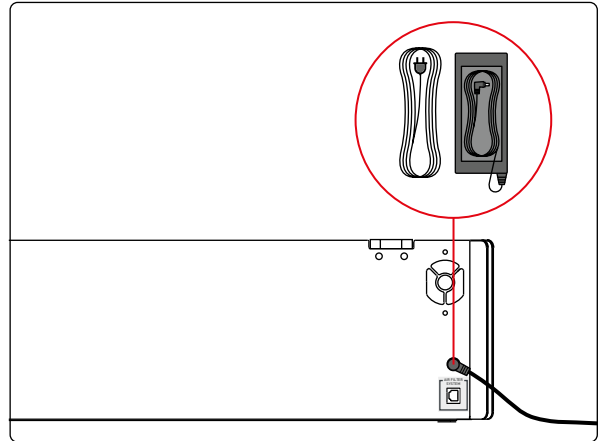

## 2. Insert key

To prevent your Mr Beam from being switched on accidentally, it is switched on/off with the help of a key switch. Insert the key into the key switch (horizontal key position with „nose up“). Note: The key can only be inserted into the switch in one position.

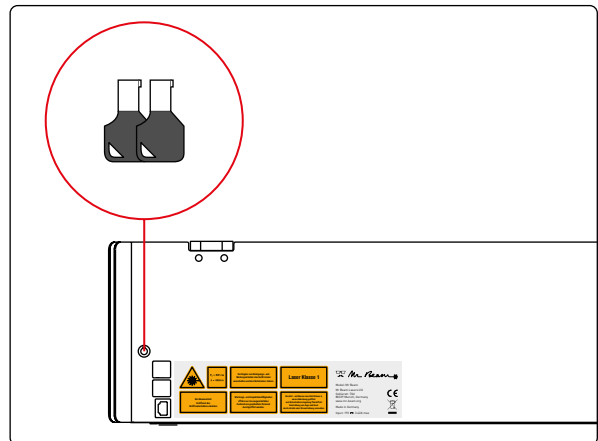

## 3. Turn the key

Turn the key clockwise to start your Mr Beam. To turn it on, briefly press the button. The light of the laser head is switched on immediately and after 10 seconds the Status Lights are also switched on. When switched on, the key cannot be removed and is in a horizontal position.

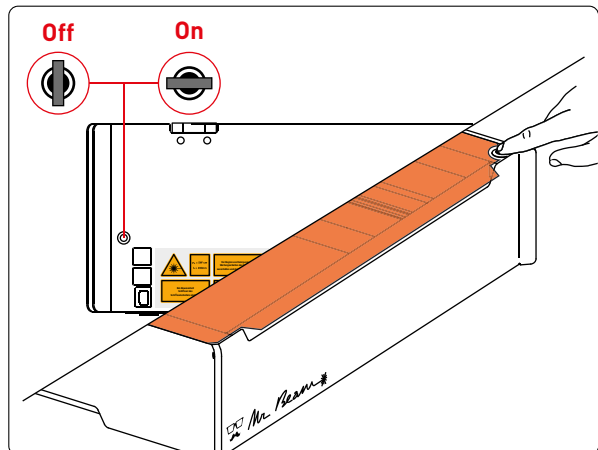



# POWERING OFF

## 1. Shut down

To properly turn off your Mr Beam after work, please shut it down first.

You shut down your Mr Beam via the Mr Beam Laserbench software (  ->Shutdown system) or by pressing the button 5 seconds until the Status Lights turn permanently red. After 15 seconds the whole system shuts down.

*Note:* The status light also lights up in the shut down state.

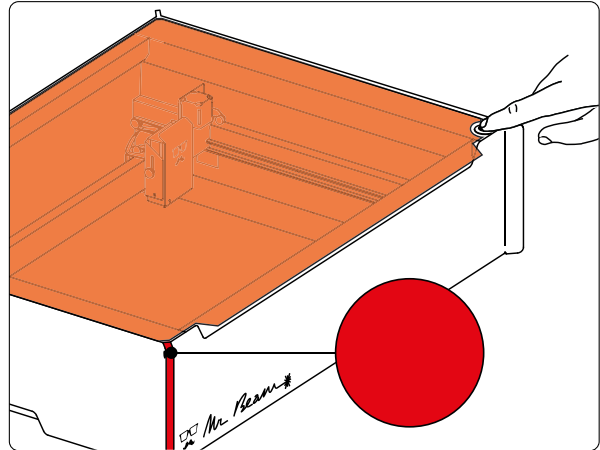

## 2. Turn off

To turn off your Mr Beam, turn the key counterclockwise. In this state, you can and should remove the key to prevent improper use of your Mr Beam.

*Note:* Please keep the key in a place that unauthorized users (e.g. children) cannot know and/or reach.

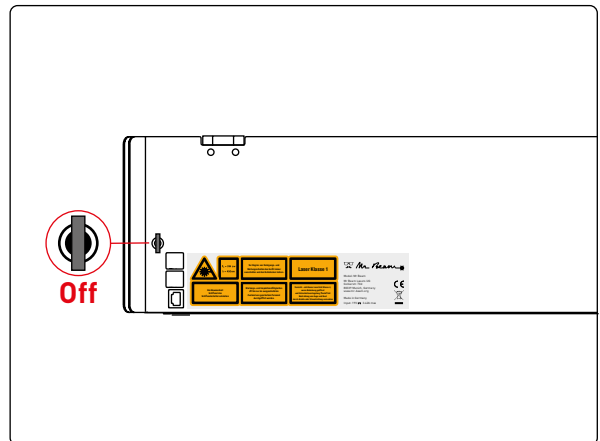

# CONNECTING TO A COMPUTER/TABLET

To operate Mr Beam and to laser files, Mr Beam must be connected to a computer/tablet. Please install the latest version of Google Chrome on the computer/tablet, as other browsers may occasionally restrict the functionality. Depending on the technical data of the computer/tablet used, different processing times may result.

*Note:* Using a more powerful computer/ Tablet will produce and display graphics faster and reduce computing and data transfer time to your Mr Beam.

## Connecting Mr Beam to a computer / tablet

There are two different options for connecting Mr Beam to your computer/tablet:

### Option 1

Connection via router (p.37-41)

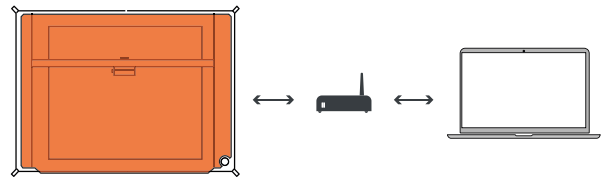

### Option 2

Direct connection (p.42-43)

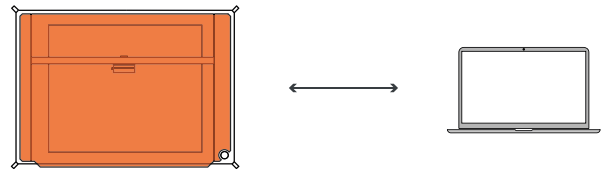

# OPTION 1

## CONNECTION VIA ROUTER

There are two different options for connecting Mr Beam via router:

### Option 1.1

Mr Beam -> WiFi -> router -> WiFi/network cable -> computer/tablet

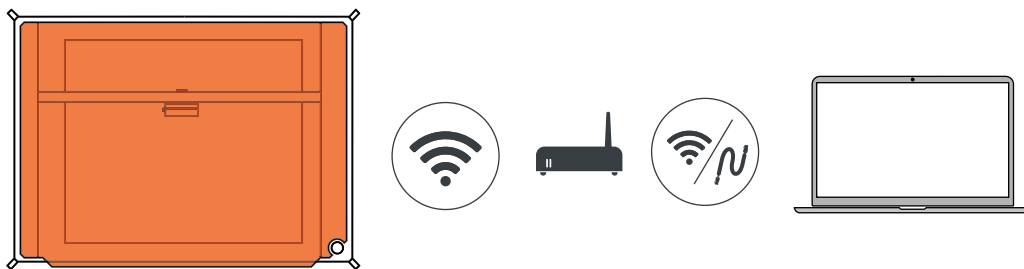

### Option 1.2

Mr Beam -> network cable -> router -> WiFi/network cable -> computer/tablet

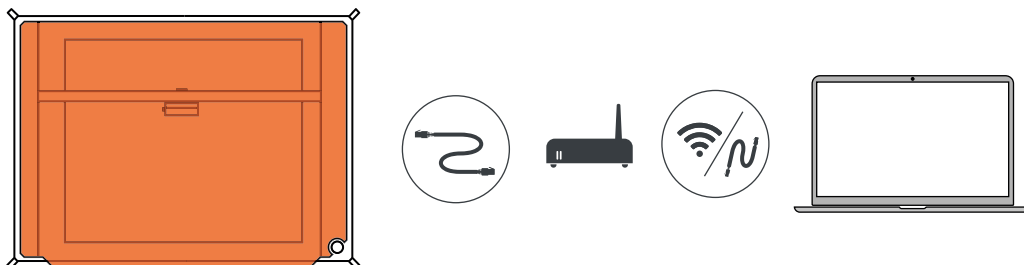

*Note:* When using an network cable, it must be shielded and not longer than 1.5 meters (4.9 feet).

### Connecting several Mr Beam

If you want to connect and set up several Mr Beam to your network, please perform the following steps for each Mr Beam completely and one after the other.

# OPTION 1.1

## CONNECTION VIA ROUTER AND WIFI

### Turn on Mr Beam

Turn on your Mr Beam and wait for 60 seconds.

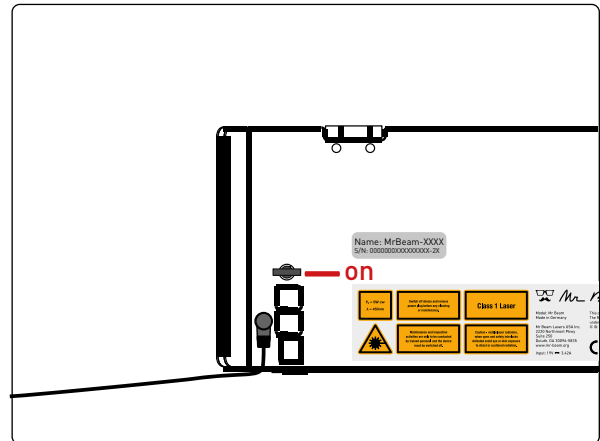

### WiFi access point

Your Mr Beam will now start a WiFi access point named MrBeam-XXXX. XXXX stands for your specific device name, which is located on the back of your Mr Beam and will be used severally in the following.

Name: MrBeam-XXXX  
S/N:0000000XXXXXXXX-2X

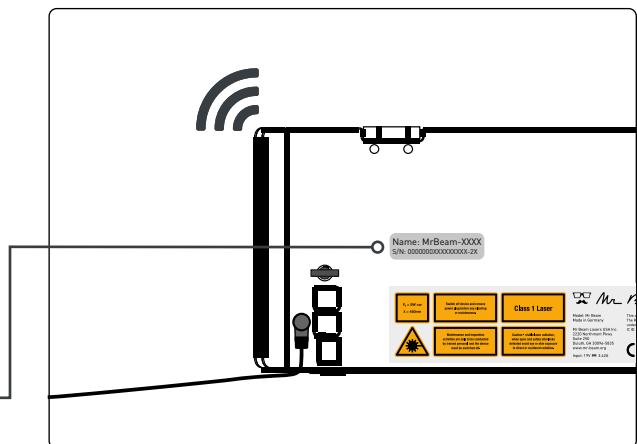

### Connect to Mr Beam's WiFi

Leave your current WiFi network and connect your computer/tablet to your Mr Beam WiFi using the following WiFi network and password:

WLAN: MrBeam-XXXX  
Password: mrbeamsetup

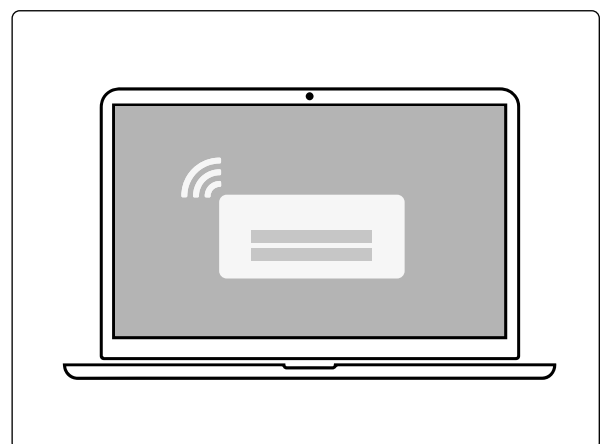

# OPTION 1.1

## CONNECTION VIA ROUTER AND WIFI

### Connecting to your Mr Beam

Enter `find.mr-beam.org` or `mrbeam-XXXX.local` into your Google Chrome browser to connect to your Mr Beam.

If you are connected directly to your Mr Beam via WiFi, it can also be accessed via the following IP address: `10.250.250.1`



### Mr Beam Welcome Dialog

Your Mr Beam will now guide you through the Mr Beam Welcome Dialog.

Please have your personal WiFi password and name ready.

After completing the Mr Beam Welcome Dialog, you can switch back to your personal WiFi network with your computer/tablet.



### Accessing your Mr Beam

If you have turned on your Mr Beam and connected it to the local network in the Welcome Dialog, it is listed in your browser at `find.mr-beam.org` and can be opened from there<sup>1</sup>.

Alternatively, it can be accessed directly via the address: `mrbeam-XXXX.local`<sup>2</sup>. XXXX will be replaced by your specific device name located on the back of your Mr Beam.



<sup>1</sup> If your local network is connected to the Internet and your Mr Beam and your computer are on the same network

<sup>2</sup> Applies to common network configurations

# OPTION 1.2

## CONNECTION VIA ROUTER AND NETWORK

### Turn on Mr Beam

Turn on your Mr Beam and connect it to your router via network cable (Ethernet). The network socket is located next to the power socket. Then wait 60 seconds.

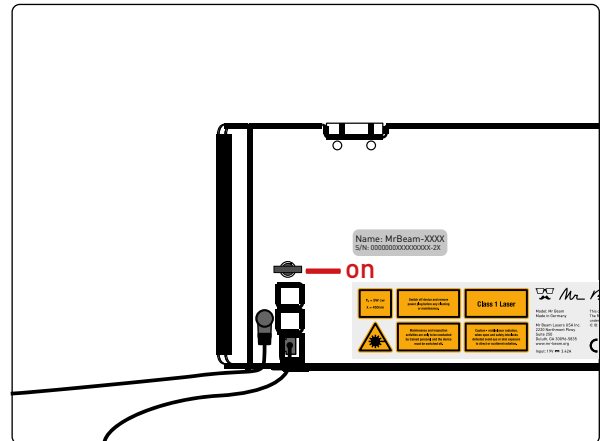

### Device name

On the back of your Mr Beam is your specific device name MrBeam-XXXX, which will be used severally during the following.

Name: MrBeam-XXXX  
S/N:0000000XXXXXXXX-2X

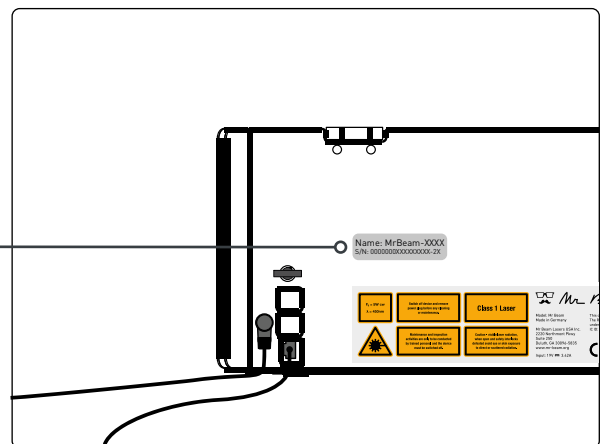

### Connect your computer/tablet to the router

Make sure that your computer/tablet is also connected to the router via WiFi or cable.

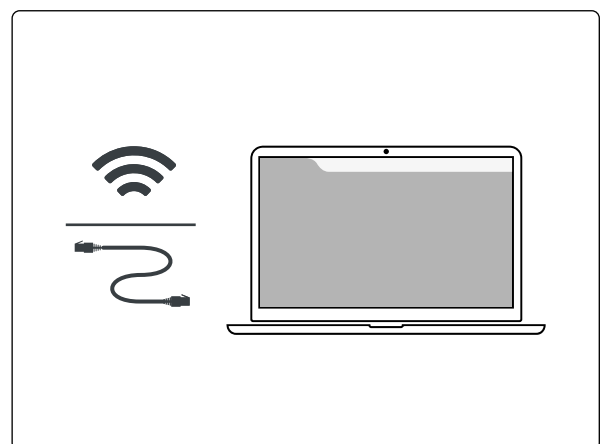

# OPTION 1.2

## CONNECTION VIA ROUTER AND NETWORK

### Connecting to your Mr Beam

Enter `find.mr-beam.org` or `mrbeam-XXXX.local` into your Google Chrome browser to connect to your Mr Beam.

On a Windows PC, you can also access your Mr Beam via the network.

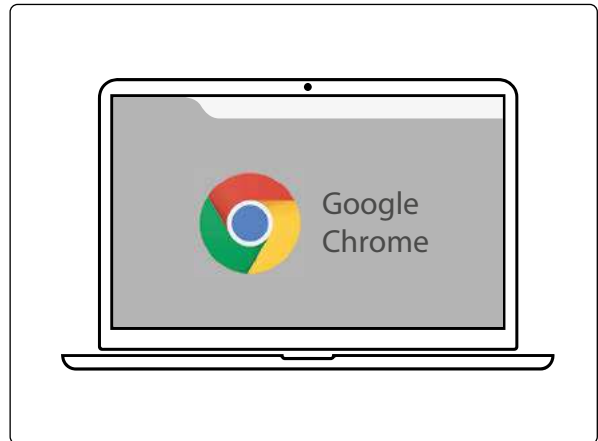

### Mr Beam Welcome Dialog

In the browser, your Mr Beam will guide you through the Welcome Dialog.

Optionally, you can integrate Mr Beam into your WiFi. Have your personal WiFi password ready for this.



### Accessing your Mr Beam

If you have turned on your Mr Beam and connected it to the local network in the Welcome Dialog, it is listed in your browser at `find.mr-beam.org` and can be opened from there<sup>1</sup>.

For use without the Internet, it can also be accessed directly via the address: `mrbeam-XXXX.local`<sup>2</sup>.

XXXX will be replaced by your specific device name located on the back of your Mr Beam.



<sup>1</sup> If your local network is connected to the Internet and your Mr Beam and your computer are on the same network

<sup>2</sup> Applies to common network configurations

# OPTION 2

## DIRECT CONNECTION

### Turn on Mr Beam

Turn on your Mr Beam and wait for 60 seconds.

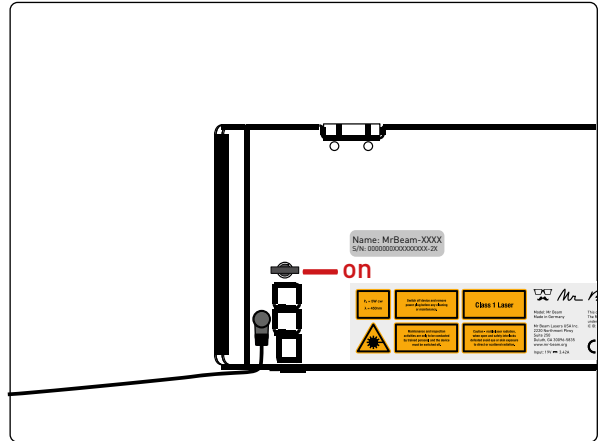

### WiFi Access Point

Your Mr Beam will now start a WiFi access point named MrBeam-XXXX. XXXX stands for your specific device name, which is located on the back of your Mr Beam and will be used severally in the following.

Name: MrBeam-XXXX  
S/N:0000000XXXXXXXXXX-2X

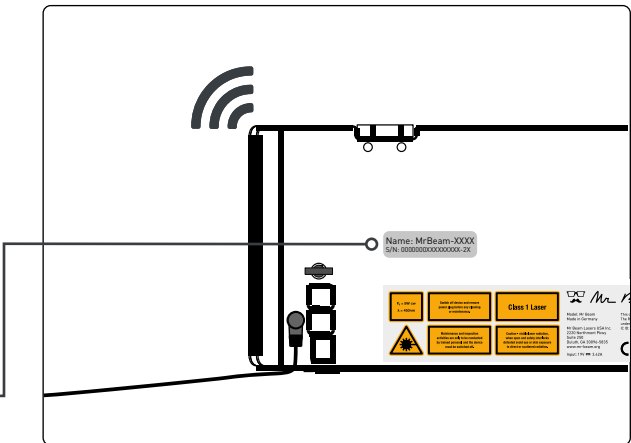

### Connect to Mr Beam's WiFi

Leave your current WiFi network and connect your computer/tablet to your Mr Beam WiFi using the following WiFi network and password:

WLAN: MrBeam-XXXX  
Password: mrbeamsetup

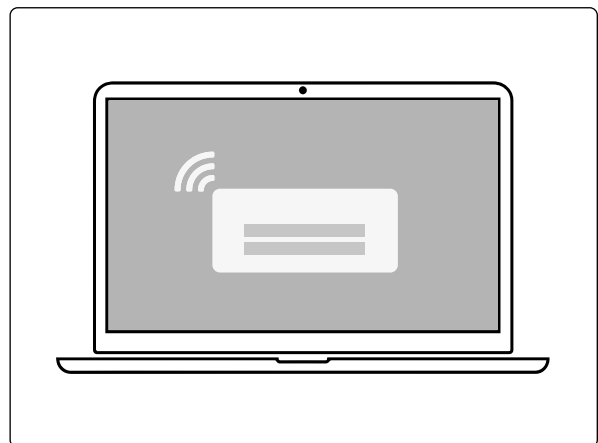



# OPTION 2

## DIRECT CONNECTION

### Connecting to your Mr Beam

Enter `find.mr-beam.org` or `mrbeam-XXXX.local` into your Google Chrome browser to connect to your Mr Beam.

If you are connected directly to your Mr Beam via WiFi, it can also be accessed via the following IP address: `10.250.250.1`

*Note:* A direct connection via network cable is not supported.





# Chapter 05

## S O F T W A R E M R B E A M L A S E R B E N C H

---

Thanks to the integrated camera and the intuitive user interface, anyone can quickly learn how to operate Mr Beam.

The following chapter explains the Mr Beam software (Mr Beam Laserbench) in detail.

# MR BEAM LASERBENCH

Continue to Laser Job Parameters

Working area

Upload and select a design

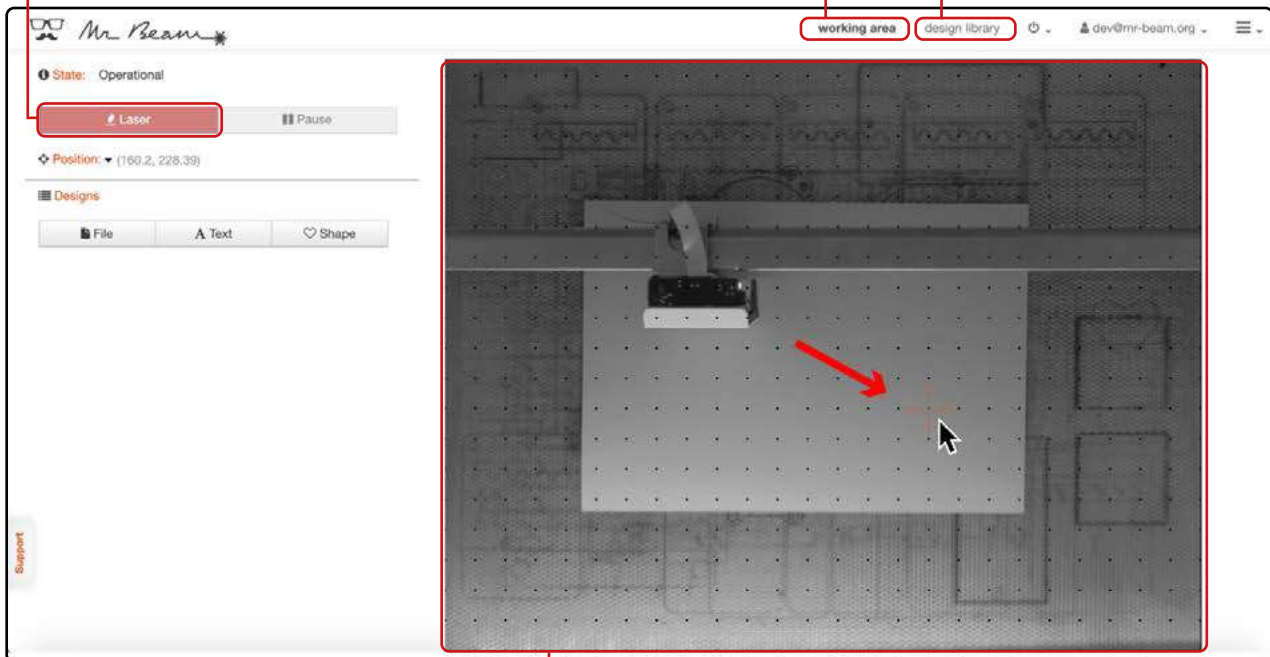

When the lid of Mr Beam is fully open, a photo is taken every five seconds and it is shown on the working area. Double-click anywhere to move the laser head to the desired position.

## 1. File upload

Now switch to the workspace „Design Library“. Under „Upload“, you can select or drag&drop a file into the browser window. Files with the extensions .dxf, .svg, .g, .gco, .gcode, .gif, .jpe, .jpeg, .jpg, .bmp, .nc, .pcx, .png, .webp can be uploaded. These are then available for selection on the right.

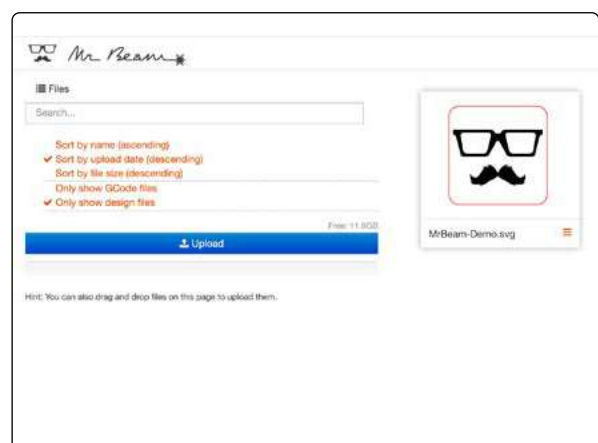

# MR BEAM LASERBENCH

## 2. Positioning

Once a file has been selected, it can be placed in the workspace on the workpiece. Use the arrows to scale and rotate the graphic.

Click on „Laser“ in the upper left corner to access Laser Job Parameters.

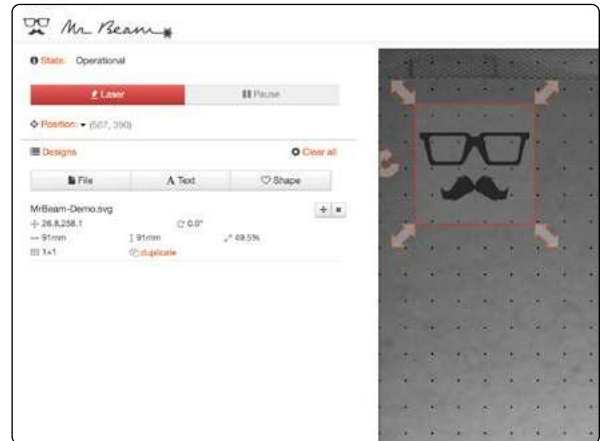

## 3. Laser Job Parameters

Select the material you have inserted. Depending on the material, colour and thickness of the material can be selected. The default values can then be manually adjusted.

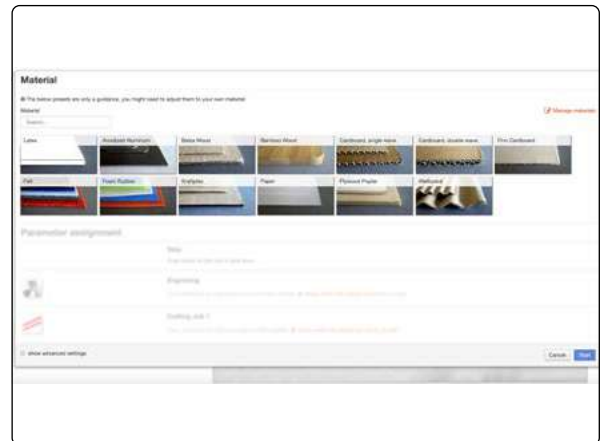

## 4. Color assignment

Depending on the material used, further settings can be configured. If different colours were used in the selected file, different parameters can be assigned. By dragging into the corresponding field, you can assign „skip“, „engrave“ or „cut“ to the colours.

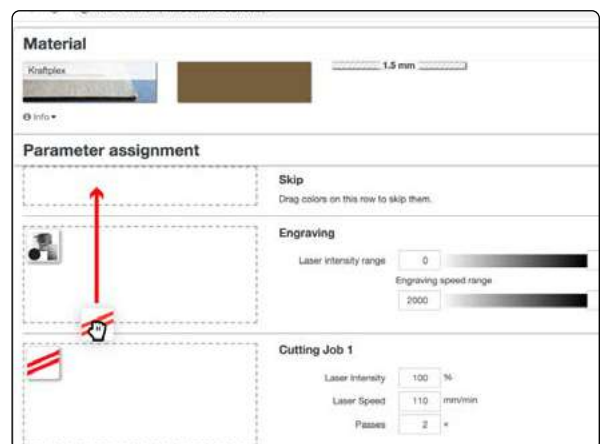

# MR BEAM LASERBENCH

## 5. Additional settings

The „Laser Intensity Range“ describes the range of the gray levels displayed in an engraving, while „Engraving Speed Range“ describes the speed at which gray values are engraved. When cutting materials, „Laser Intensity“ represents the power, „Laser Speed“ the speed and „Passes“ how often the contour is cut. Further explanations can be found under the menu item „show explanations“.

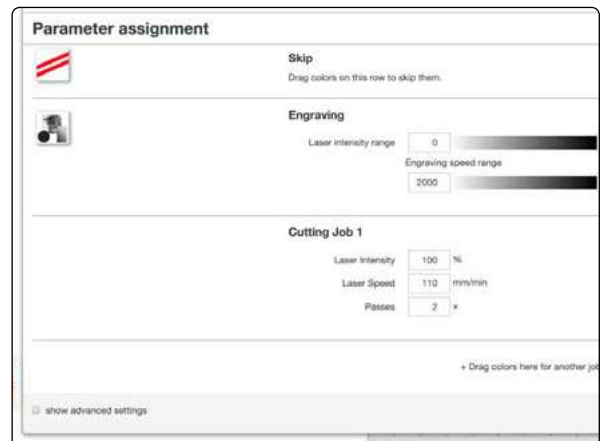

## 6. Transmission

Click on „Start“ to prepare the laser job for Mr Beam.

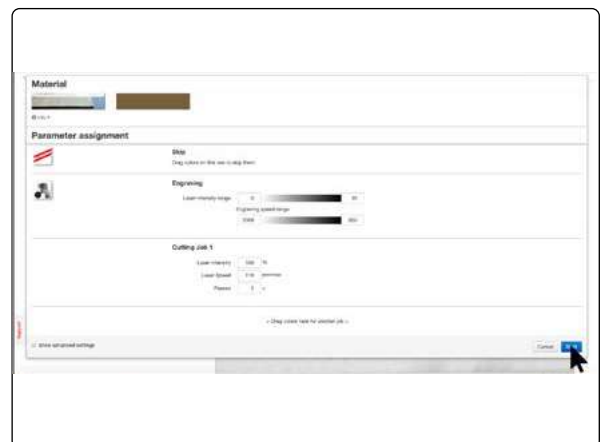

## 7. Start

After the cover of the laser has been closed and the confirmation button pressed, Mr Beam will begin the laser job.



# SOFTWARE UPDATE

A software update requires an active internet connection. Follow Chapter 4 „Setup Procedure“ to establish an appropriate connection to your Mr Beam and the internet. When a software update is available, a message appears on the Mr Beam Laserbench at the upper right corner.

To start the software update, click on „Update now“. Your Mr Beam will install the software update automatically and then shutdown. You can now reboot your Mr Beam using the key.





# WORKING WITH YOUR MR BEAM

---

After the introduction to Mr Beam Laserbench, now the first steps in material selection, suction and focusing follow.  
Time for your first laser job!

# FOCUSING

Focusing the laser head is required to achieve optimal results with your Mr Beam.

Since the laser light leaves the laser head in a cone shape, there is only one point at which it is bundled to the maximum, the focus point. In this point your Mr Beam has the maximum performance and highest precision. Therefore, the focus point should be at the height of the material to be processed. To do this, the laser head must be manually adjusted to the material height.

For best results, the distance between the lower edge of the laser head and the upper edge of the material to be processed must be 10mm. Use the Mr Beam Focus Tool for this.

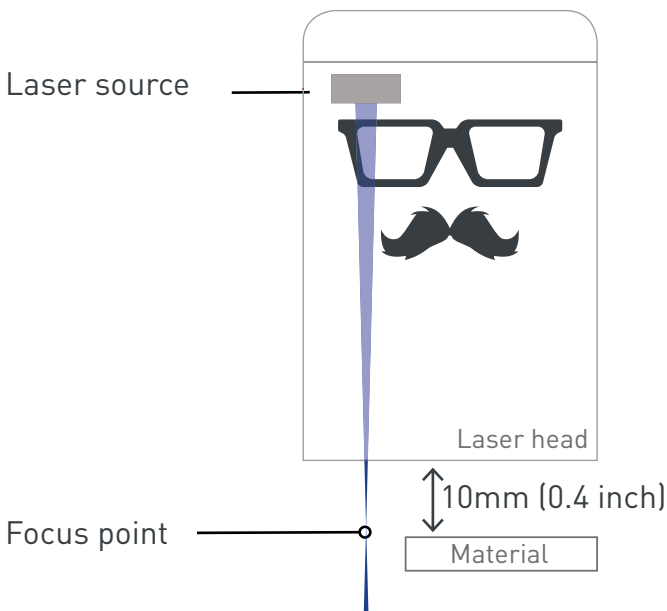

## Coarse focusing

There are four stages for coarse focusing of the laser head. For this purpose, the laser head can be mounted in different positions on the carriage of the X-axis of your Mr Beam. This is done without tools by simple form-fitting. It is not necessary to disconnect the ribbon cable.

*Warning:* The ribbon cable may only be plugged in and out if Mr Beam is shut down and turned off!

Failure to do so will result in the inoperability of Mr Beam!



## Fine focusing

The fine focusing is done by a thumb screw on the laser head as shown in the illustrations.

Note: The focus must be readjusted each time the material is changed.

### Detailed explanation

An explanation with video on the topic „Focusing“ can be found online at :

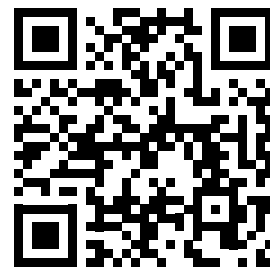

<https://youtu.be/rxRGjupnpLU>

# FOCUSING

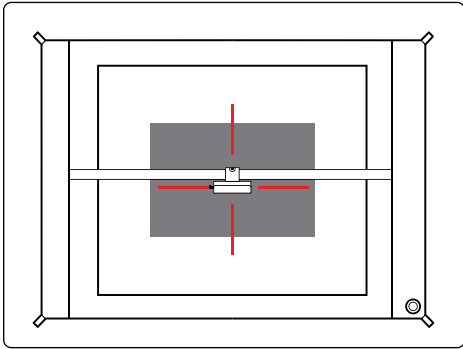

**1. Position the laser head**  
Move the laser head over the material by double-clicking on the working area.

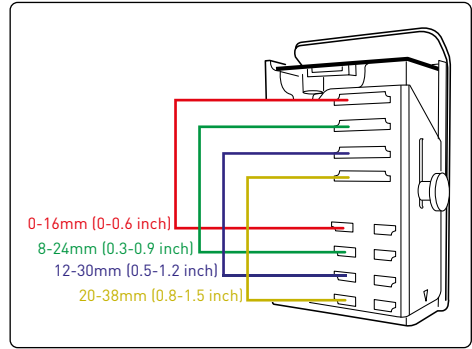

**2. Coarse focusing**  
The laser head can be mounted at four different positions for coarse focusing.

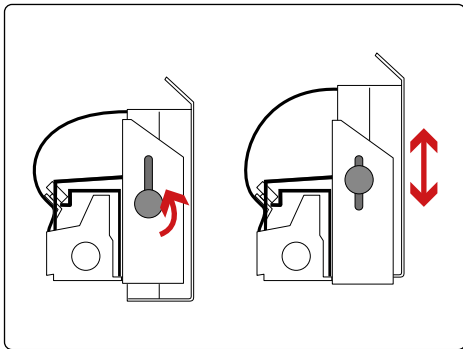

**3. Precision focusing**  
Open the screw on the left side of the laser head to move it up and down.

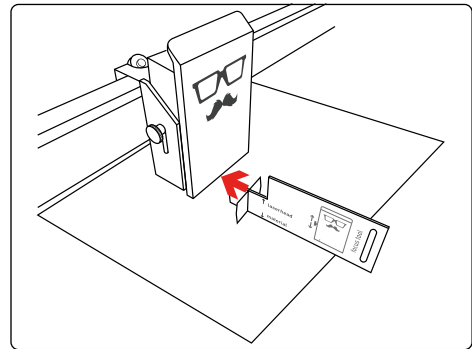

**4. Positioning focus tool**  
Place the focus tool on the material and the cross under the laser head.

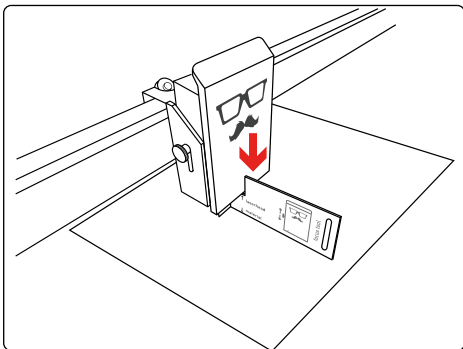

**5. Move the laser head**  
Move the laser head down until it touches the cross of the focus tool.

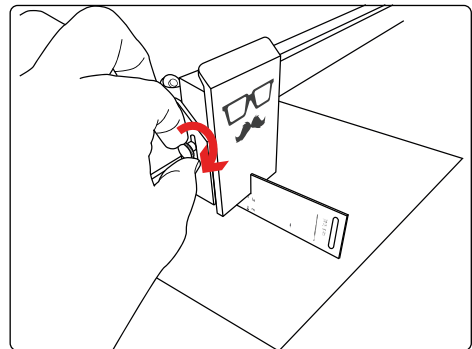

**6. Fixing the laser head**  
Tighten the screw again moderately and remove the focus tool.

# MATERIALS & SIZE OF WORKPIECE

As already described in Chapter 2 „Safety & Conformity“, hazardous vapors can be generated during laser cutting of certain materials. Therefore, it is particularly important to process only materials that have been declared suitable by Mr Beam Lasers GmbH. An updated list of materials can be found online at the following link: [www.mr-beam.org/en/materials/](http://www.mr-beam.org/en/materials/)

Before commissioning Mr Beam, the user must clarify whether harmful substances can be produced by processing the materials used. If persons, your Mr Beam and/or the Mr Beam Air Filter System can be harmed by this, these materials can't be processed. If the Mr Beam Air Filter System cannot filter out harmful substances, it is not possible to use these materials. It should be noted that it is the responsibility of the user to comply with national and regional thresholds for dust, smoke and gases. Commissioning of Mr Beam is only permitted with an appropriate suction system (see Chapter 4 „Setup procedure“). For information on how and at what intervals to change the filter, please refer to Chapter 2 „Safety & Conformity“.

## **Maximum size of workpiece**

The maximum size of the workpiece is 500 x 390 x 38 mm (19.7 x 15.4 x 1.5 inches) in length, width and height. Due to edge blurring of the camera, positioning in the center of the working surface is recommended for smaller workpieces.





# MAINTENANCE & CARE

---

Regular maintenance and care is essential to ensure that your Mr Beam functions correctly and permanently.

The following chapter contains information on proper cleaning.

# REGULAR MAINTAINANCE & CARE

Regular maintenance and care is necessary in order to maintain the high quality results of your Mr Beam. In addition, depending on the application and materials used, regular general cleaning is necessary. Always turn off the unit and disconnect the power plug before commencing cleaning and maintenance work.



*Warning:* There is a fire hazard due to insufficient cleaning and remaining pieces inside Mr Beam.

## **Regular maintenance & care**

Please check before each use if dust has accumulated in the interior of your Mr Beam. If dust has accumulated, your Mr Beam must be cleaned. Regular/daily cleaning is recommended, the degree of soiling strongly depends on the material used. Only a regularly cleaned machine can guarantee the best work performance with optimum results.

To prevent dust from entering the inside of Mr Beam when not in use, keep the lid closed as often as possible.

Do not use aggressive or chlorine-containing cleaning agents for cleaning. We recommend a mild soapy solution or the use of commercially available detergent in low concentrations.

Improper handling of chemicals can cause damage to property and personal injury for which the user alone is liable.

No tools are required for regular cleaning and no parts need to be unscrewed.

Cleaning includes:

- Remove all materials, dirt particles and deposits from the interior of your Mr Beam
- Vacuum the working area to remove residues from the grid floor
- Dust all visible parts and surfaces of your Mr Beam
- Clean the safety cover only with a cotton cloth/microfiber cloth. Do not use paper towels as they may scratch the acrylic

## **Caring of the guide bar**

The mechanical guide bar must be regularly cleaned of dust and dirt with a dry cloth.

The guide bar must be oiled approximately every 100 operating hours. Please note that a small amount of machine oil (one to two drops per rod) is sufficient. Only use acid-free oils.



# CLEANING LASER HEAD

The dirt residue from cutting through different materials gets inside the laser head, which leads to heating up and scorching of these dirt particles on top of the laser lens. Additionally, the air cannot circulate properly inside the laser head casing, which affects the overall performance. The laser head should be cleaned after approx. 100h of service, however this is just a rough guide value. The best indicator is a considerable decline in the cutting power of the laser. A average life span of the laser diode is 10.000 h. In this tutorial we will show you how to clean the laser head and what to pay attention to.

By the end of it you will be able to take the laser head of your Mr Beam apart, remove the dirt, assemble it, and put it back to work safely. And if you think it looks too complicated, you can still make use of our Mr Beam maintenance service (You will find more details in our shop [www.mr-beam.org](http://www.mr-beam.org)).

*Note:* You should treat all parts very carefully while cleaning the laser head on your own, in order not to break anything.

## Required Tools

1. Keyboard vacuum cleaner
2. filter mask
3. gauze compress
4. cotton swab
5. Allen-key 2mm
6. safety glasses
7. glass cleaner



# CLEANING LASER HEAD

## 1. Switch off Mr Beam

Switch off Mr Beam and plug it off. Allow the laser head to rest for at least 2 minutes before proceeding with the next step, to ensure that the laser unit is fully discharged.

## 2. Move laser head

If the laser head is in the Home Position of the working area, pull it into the centre by (a) gently moving the x-axis and (b) pulling the laser head into the middle. This way you will have a better grip of the laser head.

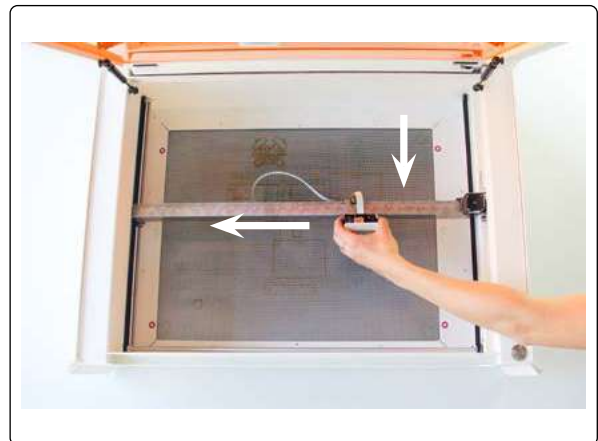

## 3. Unscrew laser head

Unscrew the laser head from the mounting bracket. Put the knurled nut back on the laser head body, this way you will avoid losing any parts during the cleaning process.

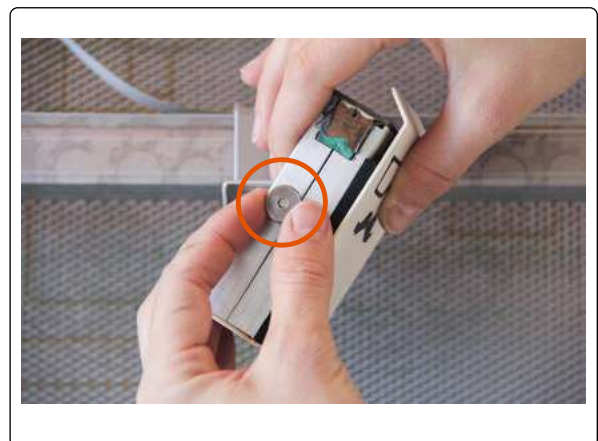

# CLEANING LASER HEAD

## 4. Unplug cable

Unplug both the cable and the hose (only in "dreamcut" model) in the back of the laser head by gently pulling it out.

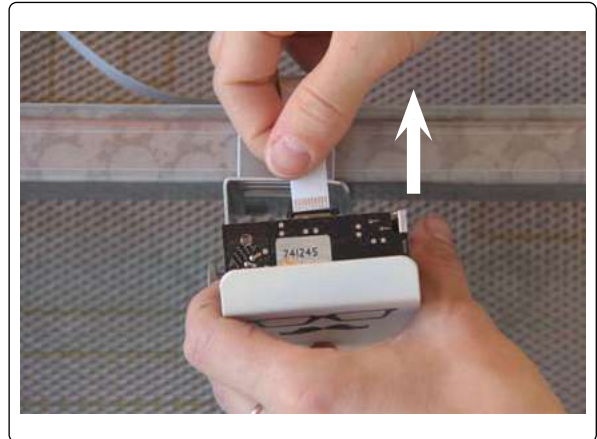

## 5. Remove screws

Remove two screws on the back of the laser head, using a 2mm Allen key. Carefully take the laserhead apart.



## 6. Laser head components

1. Laser front
2. Laser module
3. Copper block with laser
4. Fan
5. Heat sink

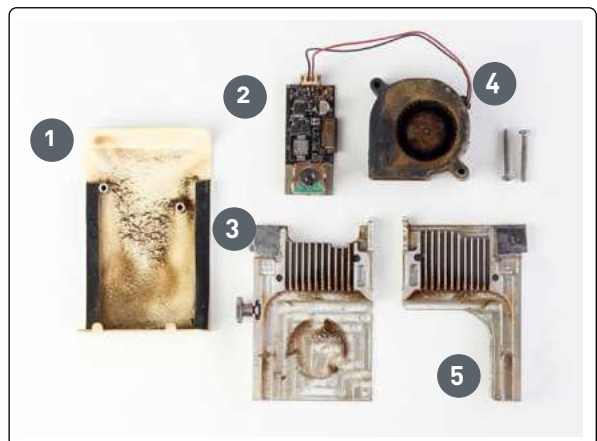

# CLEANING LASER HEAD

## 7. Pull cable off

Carefully pull the cables of the fan off, but make sure to get hold of the white pin jack, don't pull on the entire socket or directly on the cables, or they might tear!



## 8. Clean heat sink

Use a hand vacuum cleaner with a brush and clean all rilles as well as the recess for the laser channel thoroughly.



*Warning:* Make sure to wear gloves while cleaning or wash your hands thoroughly at the end of the cleaning process. Please put on a filter mask and safety glasses.



# CLEANING LASER HEAD

## 9. Clean fan

Vacuum off the dirt with a hand vacuum cleaner.



*Warning:* Hold the fan wheel with one finger to prevent it from spinning while cleaning. Otherwise the fan will spin too fast from the vacuum cleaner's air flow, and might break!



## 10. Clean laser module

Vacuum off the dirt here as well.



## 11. Clean laser lens

Wet one side of the cotton swab with a glass cleaner and carefully wipe the laser lens clean by making rotating movements with the swab. Use the other end of the swab to dry off the lens.

*Note:* Make sure not to touch the laser lens after you have cleaned it. Otherwise you will need to repeat this step.



# CLEANING LASER HEAD

## 12. Clean laser front

Vacuum off any dust particles. The laser front gets yellow and brown stains from cutting plywood. You can remove those easily by using a napkin and a glass cleaner to wipe the dirt off the laser front.



## 13. Plug in cables

Plug the wires of the fan back into the socket on the laser module. It will only work in one position, but make sure the orientation of both parts matches.

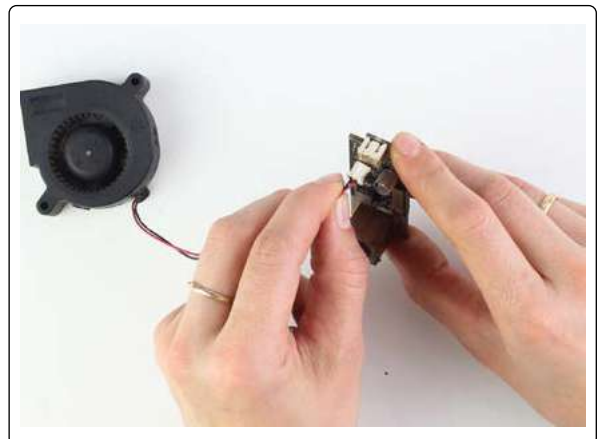

## 14. Assemble laser head

Place the fan with a hole facing the top and align the fan with the metal pin. The product label in the middle of the fan should be facing the heat sink and should not be visible.

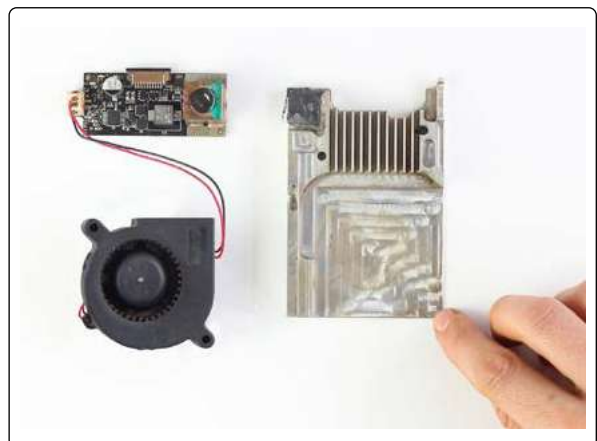



# CLEANING LASER HEAD

## 15. Assemble laser head

If it is not the case yet, screw the knurled nut on one side of the heat sink and then put both parts of the heat sink together. There should be no gaps between them.

*Note:* Make sure the fan cables run on the outside of the heat sink when both sides are put together! Make sure the heat sink closes tightly!

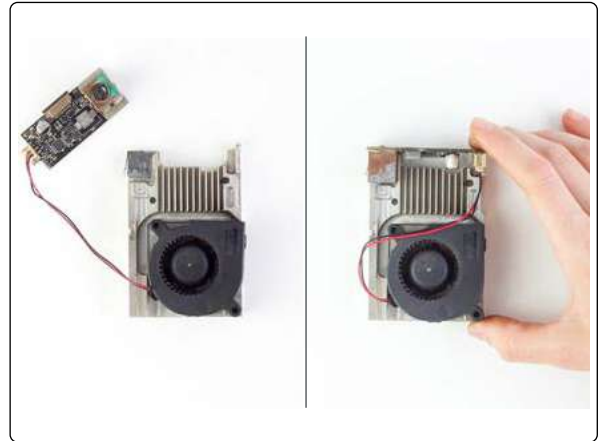

## 16. Put laser front back on

Put the laser front back on the laser head. Align the position of white threads with female screw threads of the laser head. Press the laser head against the laser front and gently to the bottom. You will hear a clicking sound indicating you assembled it correctly.



# CLEANING LASER HEAD

## 17. Align holes

*Note:* Please check that both rectangular holes pictured on the right are aligned to each other when the laser front snaps into place. There should be no overlays which make the opening for the laser channel smaller.



## 18. Tighten screws

Put the screws on the back of the laser head back in place using an Allen-key.

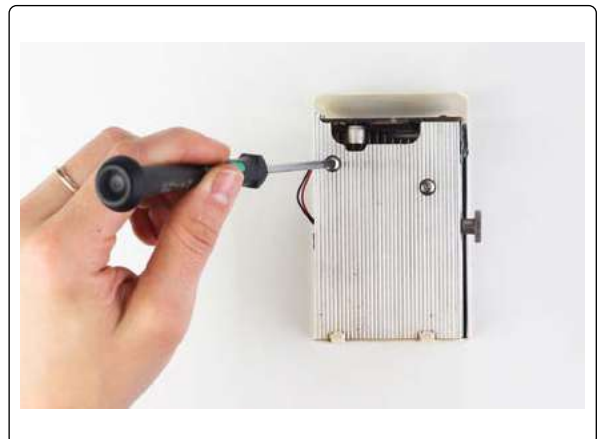

## 19. Plug in cable

Plug the white cable back into the black bracket of the laser head and insert the hose. Then screw the laser head to the mounting bracket inside your Mr Beam.

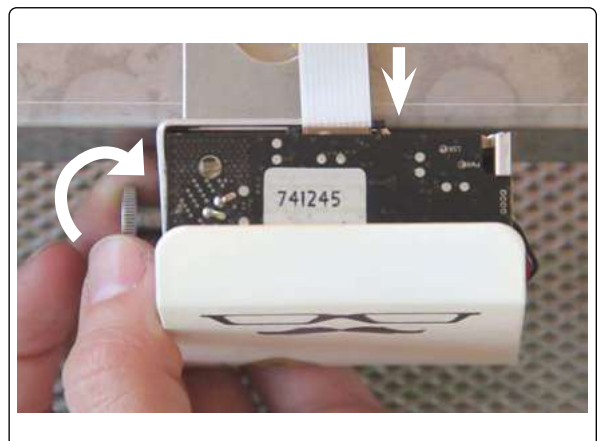



# CLEANING LASER HEAD

## 20. Camera calibration

Walk through the camera calibration with Mr Beam software. This will help align the camera image with the precise position of the laser head. Follow the instructions which you will find under *menu > settings > Camera Calibration*.



# GENERAL CLEANSING

## **General cleaning**

General cleaning is necessary at irregular intervals depending on the use of your Mr Beam and the degree of soiling. Please ensure cleanliness and clarity at and around the workplace of your Mr Beam.

General cleaning includes all the above mentioned steps of regular maintenance and care. In addition, the base plate of Mr Beam is unscrewed to remove persistent dirt between the grid floor and base plate. To do this, follow the steps on the following page.

# GENERAL CLEANSING



## 1. Loosen screws

Shut down and switch off your Mr Beam. Then remove the air hose and all other connections to your Mr Beam. Place your Mr Beam with the front side on a stable table and place a cloth underneath to prevent scratches. Unscrew all screws at the bottom plate with a 2mm (5/64 inch) Allen key. Wear gloves at all work steps to avoid injuries.

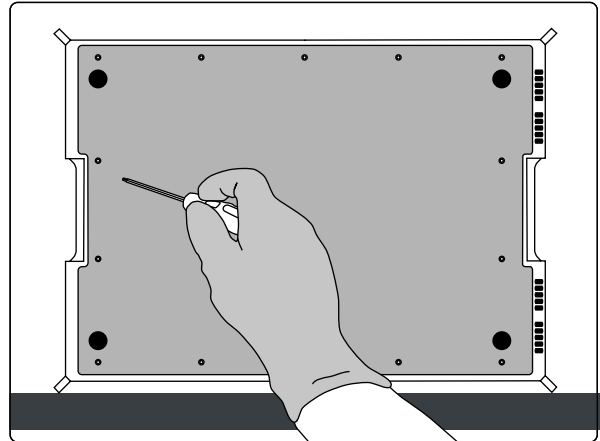

## 2. Remove base plate

Carefully remove the bottom plate.

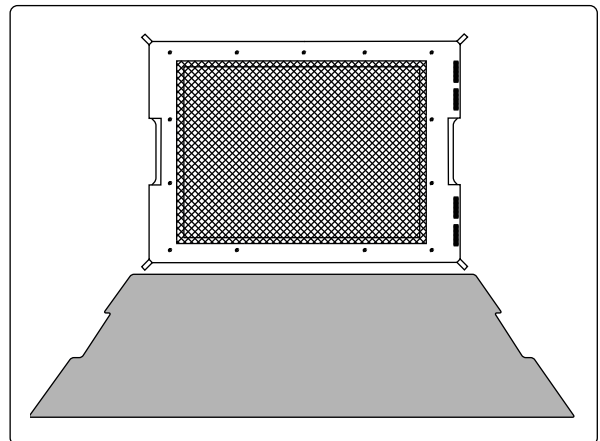

## 3. Remove grid floor

Carefully remove the grid floor. Gloves are recommended for this cleaning step. Take care not to bend the grid floor during cleaning. Then reassemble your Mr Beam in reverse order. Finally, make sure that all screws are tightened.

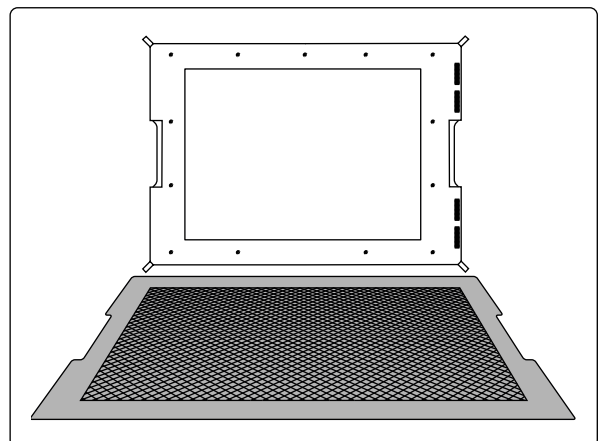

Mr Beam may only be operated when fully assembled.

# FILTER CHANGE

To ensure proper cleaning of the exhaust air by the Air Filter System, the pre-filter mat must be changed every 100 operating hours and the filter unit every 400 operating hours. A guidance can be found under Settings -> Exhaust System.

Pre-filter mats and filter units are available on the Mr Beam Online Shop: [www.mr-beam.org](http://www.mr-beam.org)

## 1. Remove the protective cover

Loosen the screws (1) and lift off the cover in the shown direction (2).

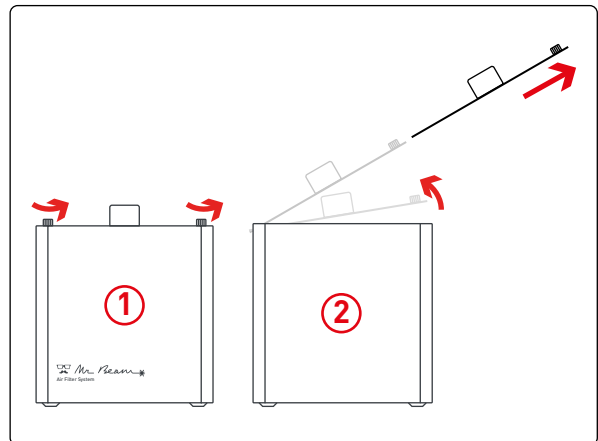

## 2. Remove filter

Remove the pre-filter (beige) and, if necessary, the filter (gray).

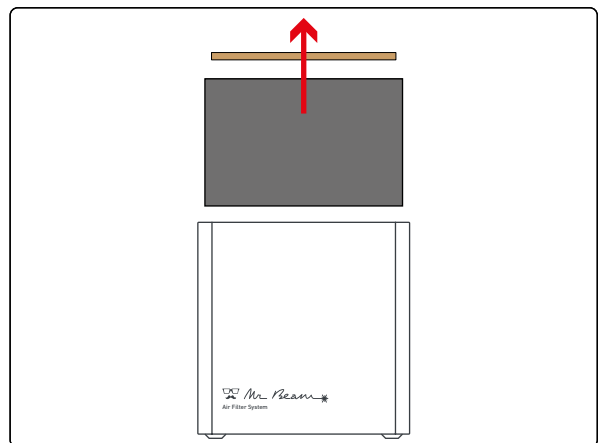

# FILTER CHANGE

## 3. Check pre-filter mat

Make sure that the pre-filter mat lies precisely on the new filter cartridge and that it covers the entire surface.

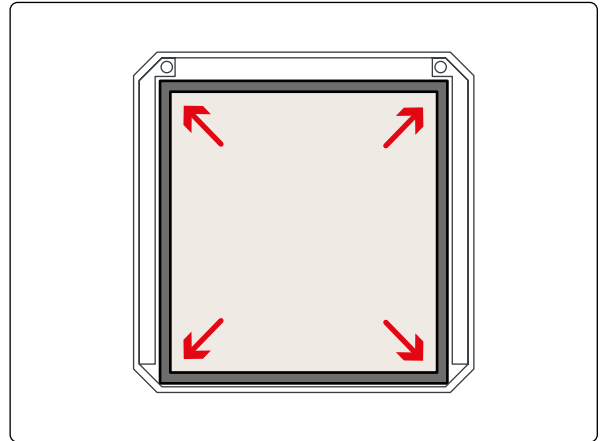

## 4. Insert filter

Insert the new filter unit including the pre-filter.

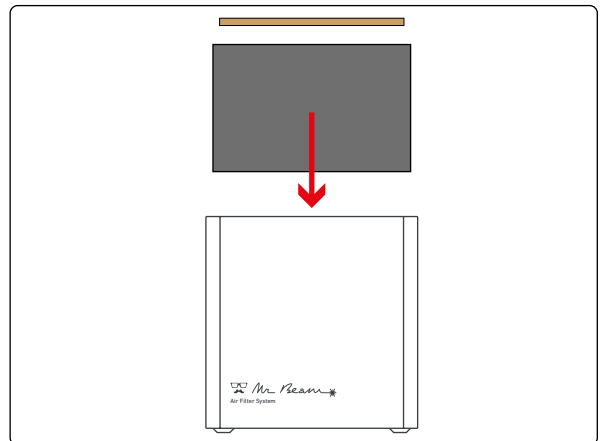

## 5. Close housing

Insert the cover (1) and close the housing and the cover with the two screws (2).

Make sure the hose is properly connected to the Mr Beam Air Filter System after changing the filter.

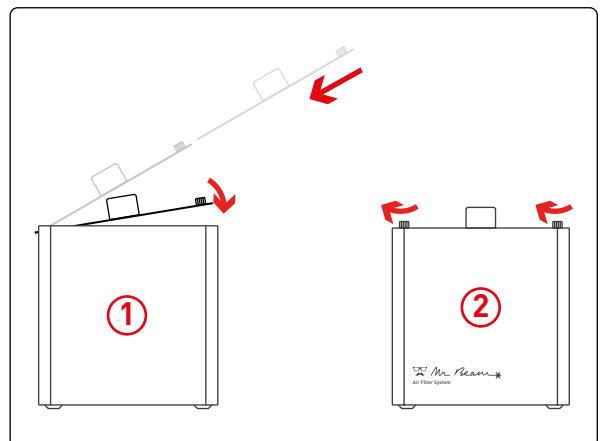

# REPAIRS

Repair of Mr Beam by the user is not intended. To ensure that your Mr Beam is quickly ready for use again in the event of a malfunction, please contact customer service: [www.mr-beam.org/ticket](http://www.mr-beam.org/ticket)







Chapter **08**

# ADDITIONAL INFORMATION

---

# TECHNICAL DATA

## Dimensions (approx.)

Width/Depth/Height	725 x 538 x 170 mm (28.5 x 21.2 x 6.7 inches)
Weight	9,5 kg (20.9 pounds)

## Ambient conditions

Ambient temperature	0 - 25°C (32 - 77°F)
Atmospheric humidity	30% - 60%

## Mechanics

Maximum size of workpiece	500 x 390 (19,7 x 15,4 inches)
Maximum workpiece height	38 mm (1,5 inches)
Maximum load on the work surface	4 kg (8,8 pounds)

## Acoustic

Maximum sound level	70 dB(A)
---------------------	----------

## Laser

Laser class of the entire device	1 (No laser protection officer is required; protective equipment is not required)
Wavelength	450 +-5 nm
Power	5 W

## Power supply

Power input	65 / 90 W (depending on equipment)
-------------	------------------------------------

*Note:* Technical data are subject to modification without notification.

# STORAGE & TRANSPORT/SUPPORT

## Storage & transport

The guidelines in Chapter 4 „Setup procedure“ must be observed for the following sub-items. In particular, the temperature and humidity must not be outside the specified range.

Please keep the original packaging and upholstery.

- If your Mr Beam remains unused for a shorter period of time (e.g. during holidays), we recommend covering it to protect it from dust and other pollution.
- To store your Mr Beam for a long period of time, it must be packed in its original packaging and not be exposed to high temperature and humidity fluctuations.
- Mr Beam must be transported and shipped in its original packaging and original upholstery. The Mr Beam must not be thrown, knocked, shaken or subjected to any other mechanical loads.

## Mr Beam Support

If you need help resolving a problem, please do not hesitate to contact Mr Beam Support at any time:

*[www.mr-beam.org/ticket](http://www.mr-beam.org/ticket)*

Please read the User Manual completely and install the latest software update before contacting customer support.

# DISPOSAL

## Disassembling, Dismantling

Mr Beam can be disposed of as a complete device. You do not have to disassemble or dismantle the unit before disposal. Only the cables and ventilation hoses can be handed over separately from your Mr Beam to the electrical equipment collection unit. Please observe the relevant guidelines for your country. If disassembling or dismantling of the device is required, please contact Mr Beam Lasers GmbH. As described in Chapter 2 „Safety & Conformity“, the user is not intended to disassemble Mr Beam.

## Disposal, environmental considerations

Mr Beam may not be disposed of with household wastes in accordance with local laws and regulations.



Your Mr Beam is an electronic  device and must be disposed of in accordance with the Electrical and Electronic Equipment Waste Directive of your country at local electrical and electronic equipment waste collection points.

For further questions please contact Mr Beam Lasers GmbH.

WEEE Number: DE17853778





Chapter 09

GENERAL TERMS AND CONDITIONS

---

# GENERAL TERMS AND CONDITIONS

The current and valid general terms and conditions of Mr Beam Lasers GmbH can be found at: [www.mr-beam.org/terms](http://www.mr-beam.org/terms)



# CONTACT ADDRESSES

Postal Adress	Mr Beam Lasers GmbH Gollierstr. 70 80339 München Germany
Mr Beam Support	<a href="http://www.mr-beam.org/ticket">www.mr-beam.org/ticket</a>
Instagram	<a href="https://www.instagram.com/mrbeamlasers/">instagram.com/mrbeamlasers/</a>
YouTube	<a href="https://www.youtube.com/c/MrBeamLasers">youtube.com/c/MrBeamLasers</a>
Facebook	<a href="https://www.facebook.com/mrbeamlasercutter/">facebook.com/mrbeamlasercutter/</a>
Twitter	<a href="https://twitter.com/MrBeamLasers">twitter.com/MrBeamLasers</a>

*We reserve the right for errors and alterations.*

