

USER MANUAL

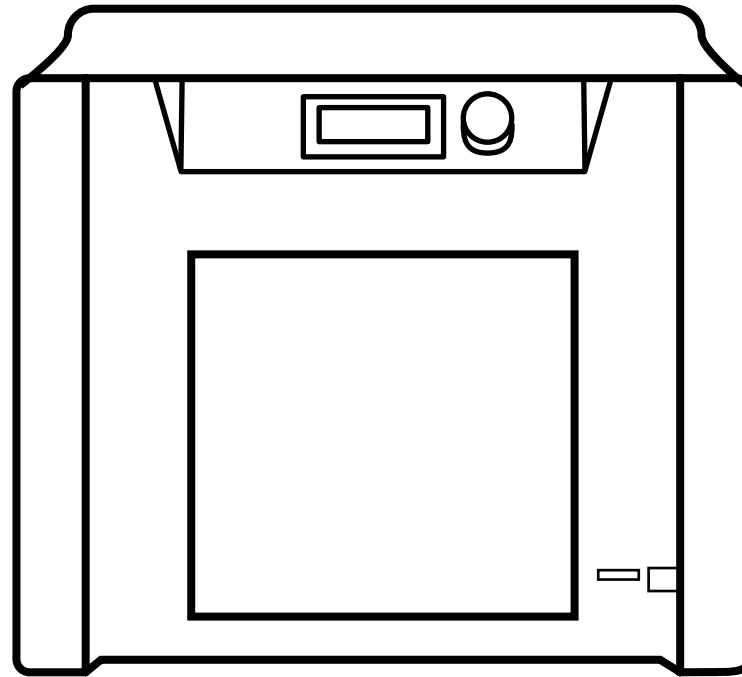

3DKreator

Kreator Motion 3D printer

Welcome

Welcome among users of
Kreator Motion 3D printer!



Read the manual of the device, all information will allow you to operate the printer easily.

Table of contents

2	Welcome	12	Display and controlling
3	Table of contents	14	Display
4	Basic information	16	Calibration of the platform
5	Kreator Motion printer	19	Installation / Change of filament
6	Technical parameters	21	Printing
8	Printing materials	22	Additional information
9	Unboxing	23	Technical support
11	First run		

Basic information

SAFETY

Before using the Kreator Motion printer, it is recommended to read the following instructions.

PRECAUTIONS

The device is powered by AC 230V / 50Hz. Connect it to a power socket with a safety pin (earth) to prevent electric shock in the event of fault.

The place of installation should meet the following conditions:

- the room must be equipped with ventilation appropriate to its size,
- the printer must be placed on a flat, stable surface.

Do not install the device:

- outdoors,
- in damp locations or places exposed to flooding,
- in the vicinity of flammable materials and heat sources.

GENERAL INFORMATION

When printing is in progress do not touch: the model, the print head and the working platform. Failure to comply with this warning may cause burns and/or deformation of the print,

- After completion of the printing wait until the printer components cool down,
- When printing, do not place other objects in the area of printer as this may damage the printer,
- Use gloves and goggles when removing the model from the platform,
- Juveniles can use the printer only under adult supervision,
- Additional tools should be kept away from juveniles.

Kreator Motion printer

SET CONTENTS

1 x

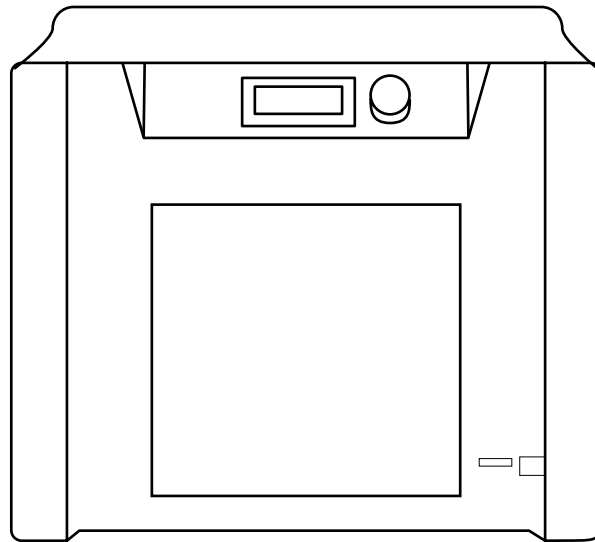

Kreator Motion
3D printer

1 x

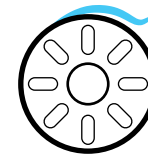

spool with filament

1 x

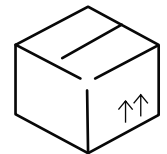

box of tools and a set
of cables

1 x



warranty card

1 x

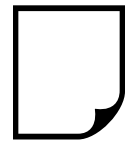

Quick Start

Technical parameters

PARAMETERS

Printing technology.....	Fused Filament Fabrication
Workspace.....	200 x 200 x 190 mm
Resolution of the print	60 microns
Precision of positioning.....	10 microns
Printing nozzle diameter	0.4 mm
Filament diameter (material).....	1.75 mm
Max temperature of the print head.....	260 °C
Max temperature of the platform.....	110 °C

POWER

Power socket.....	230 V AC / 50 Hz
-------------------	------------------

MEASUREMENTS

Size of the printer	519 x 395 x 420 mm
Size of the package	650 x 535 x 563 mm
Product weight.....	18 kg
Shipping weight.....	22 kg

TEMPERATURE

Operating temperature	15 - 35°C
Storage temperature.....	0 - 35°C

Technical parameters

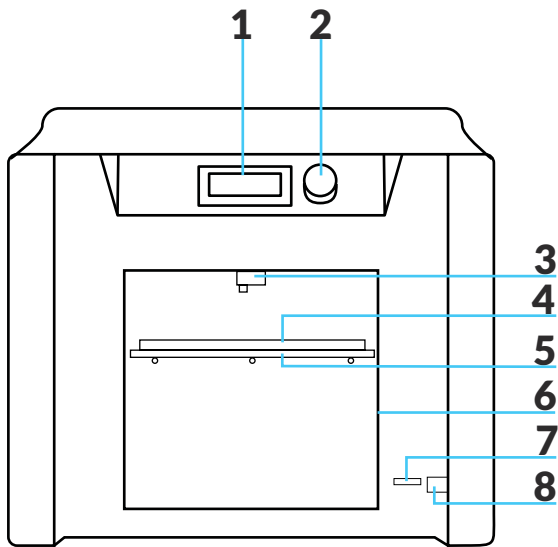

- 1. LCD screen
- 2. Control knob
- 3. Head with extruder
- 4. Table
- 5. Platform

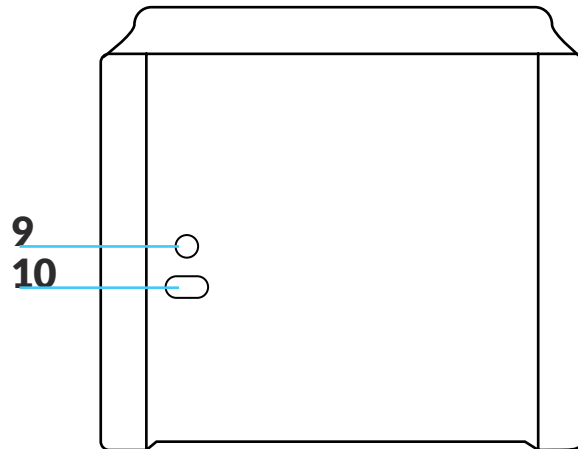

- 6. Working chamber
- 7. SD reader
- 8. USB socket
- 9. Power button
- 10. Power socket

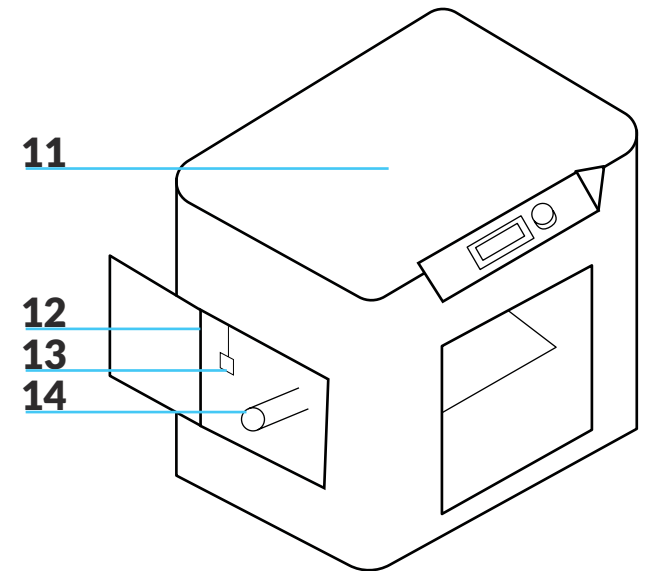

- 11. Cover
- 12. Chamber with filament
- 13. Filament sensor
- 14. Spool holder

Printing materials

3DKreator offers filaments to the Kreator Motion 3D printer. They are a guarantee of successful print and trouble-free operation of the device. For more information visit our website:

www.3dkreator.com

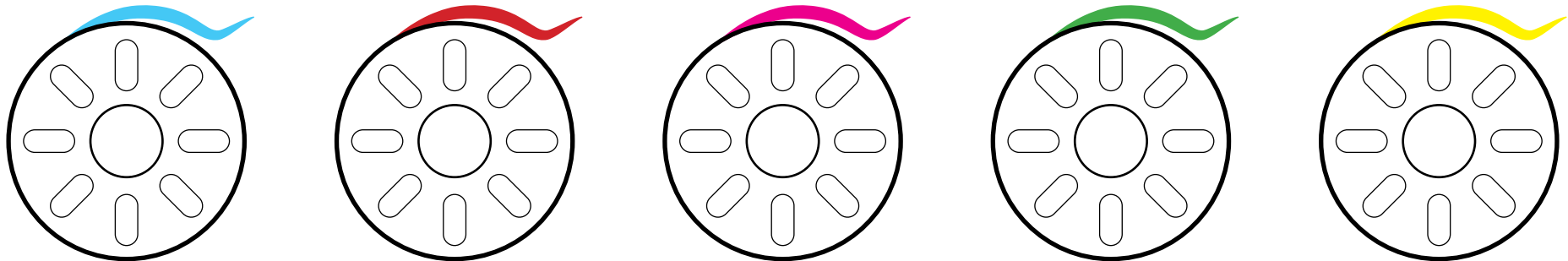

Unboxing

UNBOXING AND FIRST RUN

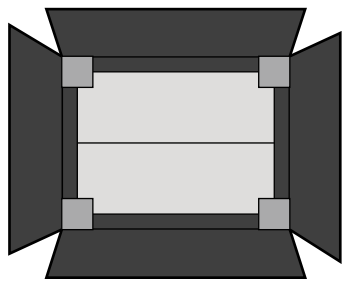

1.

1. Place the box on a flat and stable surface, then open the outer box.

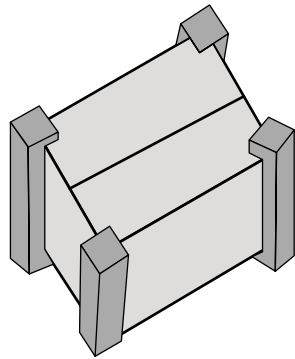

2.

2. Pull out the inner box.

4x

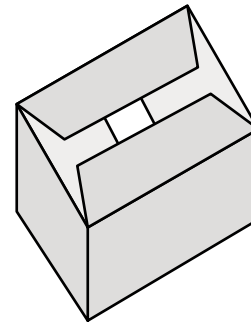
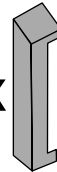

3.

3. Remove 4 cardboard package protectors.

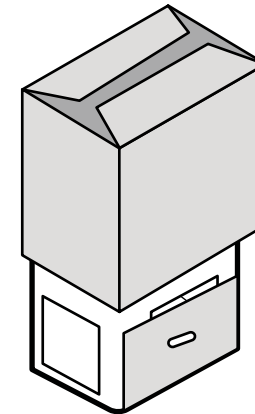

4.

4. Lift the inner box up until you see the printer. Put all of the packaging in the larger box - it'll be useful when transporting the printer.

First run

UNBOXING AND FIRST RUN

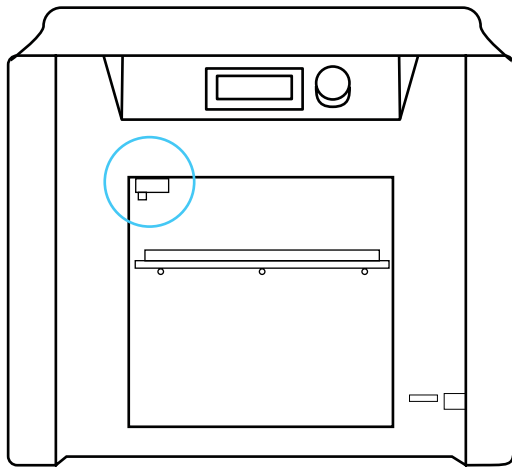

5.

5. Locate the yellow plastic transport bezel, which protects the head from moving during transport. It is marked in blue in the image.



We recommend cutting the strap on the right side of print head.

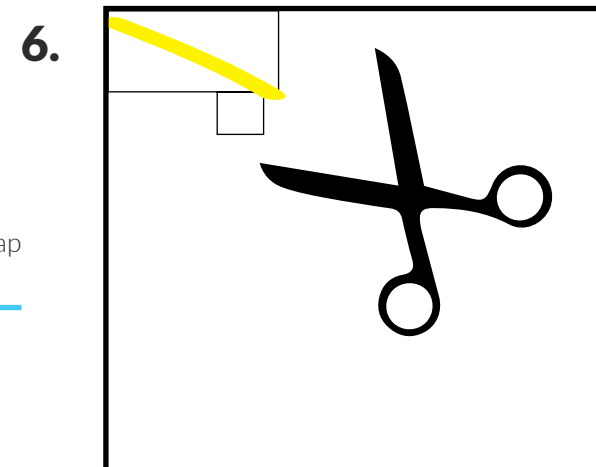

6.

6. Cut the strap and remove it from inside the printer.

First run

UNBOXING AND FIRST RUN

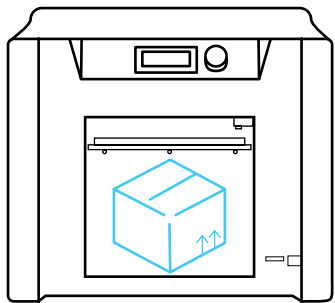

7.

7. Remove the box located under the table - you might need to use a bit of force because of the close placement of the boxes.

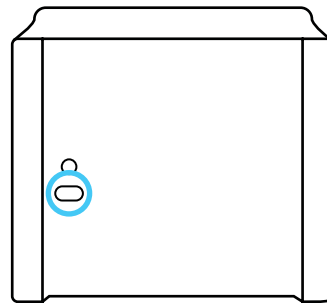

8.

8. Plug the power cord into the socket at the rear of the printer and plug into an electrical outlet.

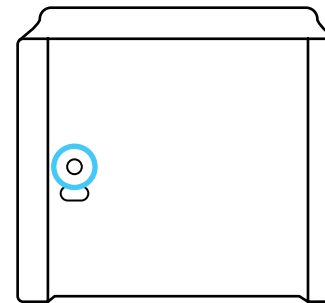

9.

9. Turn on the printer using the button located above the power socket.

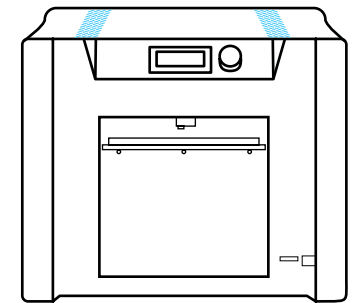

10.

10. The print chamber should light up blue, which means that it is in standby mode.

Display and controlling

FIRST STARTUP SCREEN



After starting the printer, the display shows **startup screen**.

1. Temperature of the print head: current / set.
2. Temperature of the print platform: current / set
3. Printer status
4. The current position of the table from the zero position expressed in millimetres.
5. Current print speed, the value of 100% corresponds to the speed defined for each g-code file when it is generated.

Display and controlling

SECOND STARTUP SCREEN AND CONTROLLING

Turning the control knob will start the **second** screen.

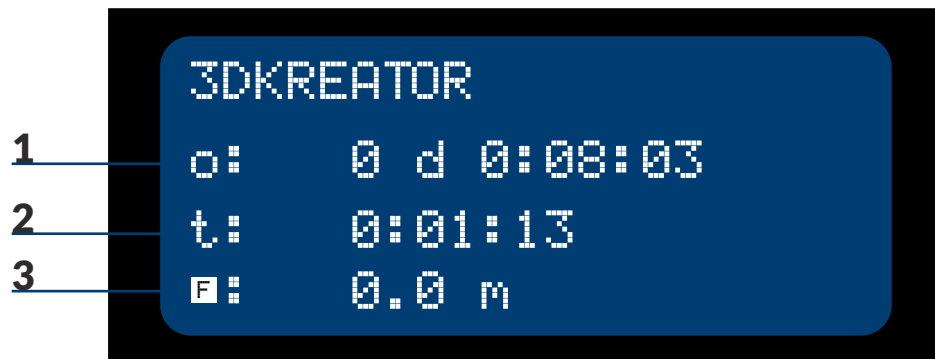

1. Total runtime.
2. The duration of current print.
3. The total amount of used material (in meters).

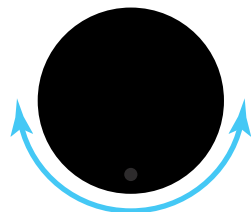

To navigate the menu use the control knob. If you turn it to the right or left you will move between the lines down or up the menu. Clicking on the knob means selection of the currently selected tab or acceptance of the given option.

Display

MAIN MENU



The main menu displays after clicking the control knob

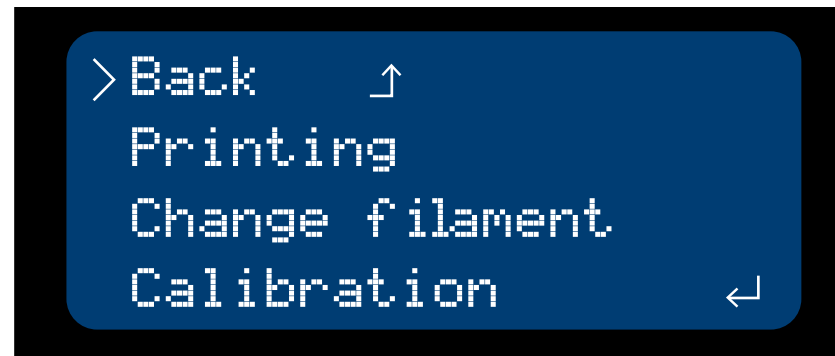

- | | |
|-------------------------|--|
| Back: | return to the main screen, |
| Printing: | the function is available only when a SD card is in the reader, it allows for selection of the used material, the temperature and start of printing, |
| Change filament: | starts the procedure for changing the filament in the printer, |
| Calibration | starts the calibration of the platform, |
| Manual control: | this tab allows the manual control of the device, changing the temperature of the head and the platform, level of cooling the printer, print speed, as well as the movement of axes. |

Display

MAIN MENU

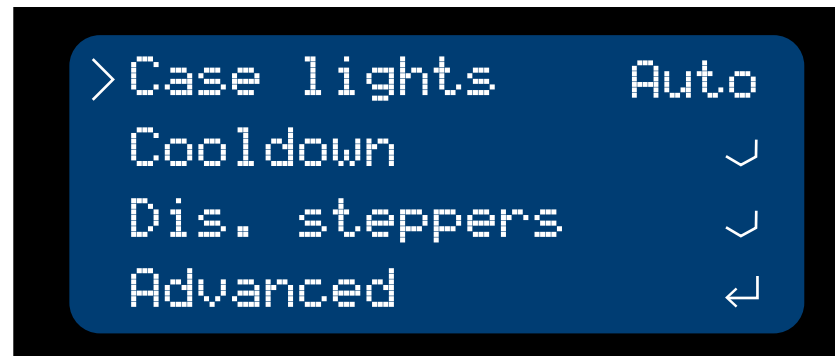

- Case lights:** printer case lights selection:
- Auto – automatic, backlight color depends on the printer status,
 - On – white color of backlight regardless of the printer status,
 - Off –backlight off.
- Cooldown:** turns off the print head and table heater,
- Dis. steppers:** turns off the power of all steppers,
- Advanced:** advanced settings.

Calibration of the platform

Calibrating the working platform is recommended when you first start the printer. Calibration of the table consists of leveling it with respect to the print head by means of three nuts located underneath the table's platform. Tightening them (turning them to the right) lowers the table, while loosening them (turning them to the left) raises the table.

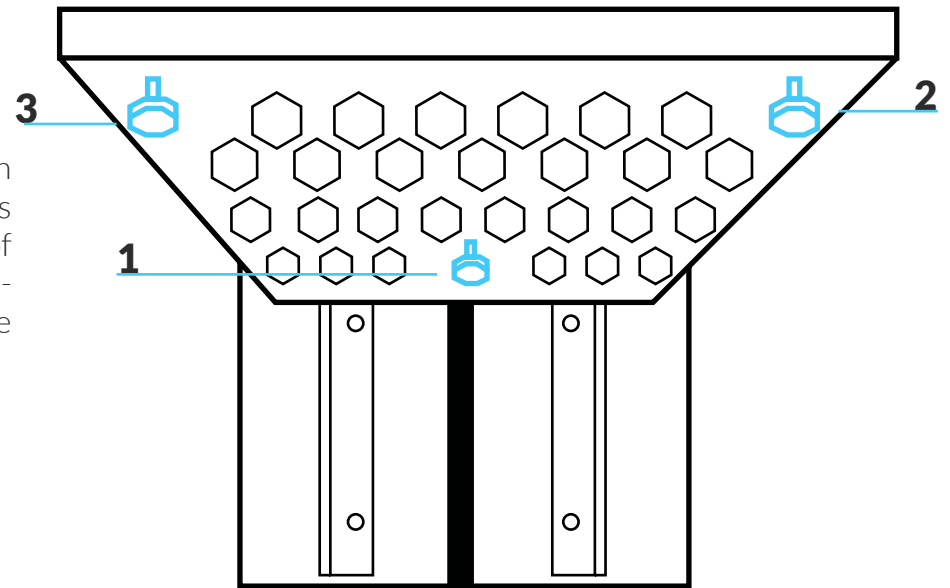

NOTICE!

During the calibration process the print head heats up to 235°C. Be careful and do not touch the head components.

Calibration of the platform

CALIBRATION PROCEDURE

1. From the main menu, select **Calibration**. The print head will travel to the front of the chamber and heat up to 235°C. Clean the nozzle with tweezers and choose **Next step**.
2. The print head will move to the first calibration point, located above nut no. 1. Turning the nut will cause the printer's backlight to change color from white to green.
NOTICE! A green light does not always mean that the printing platform is properly calibrated. If the head moves to the calibration point and printer light turns green, turn the nut to the right until the light turns white. Then turn the nut to the left.
3. A change in the back light from white to green indicates the appropriate level.
4. Choose **Next step**. The head will travel to the next position.
5. Repeat the procedure from steps 2 and 3 for the remaining calibration points.
6. After calibrating the head in the last position, choose **Exit**. The head will travel to the default position. Following this procedure, the table is correctly calibrated.

Installation / Change of filament

PROCEDURE FOR CHANGING A FILAMENT

Before the first print, a spool with filament must be installed in the printer. This option is also used to change the material to another.

1. From the main menu, select *Change filament*.
2. The print head will travel to the front of the chamber and heat up to 235°C.

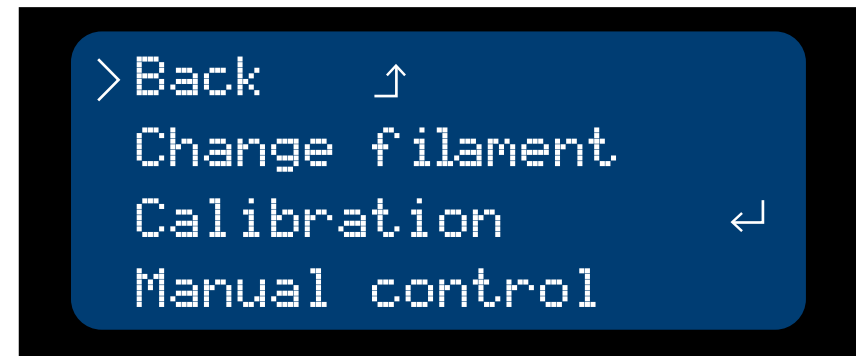

NOTICE!

During the process of changing the filament, the print head heats to temperature of 235°C. Be careful and do not touch the head components.

Installation / Change of filament

PROCEDURE FOR CHANGING A FILAMENT

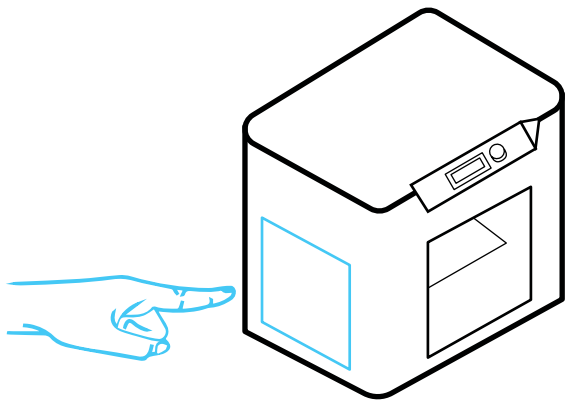

3.

3. Open the side door of the filament compartment.

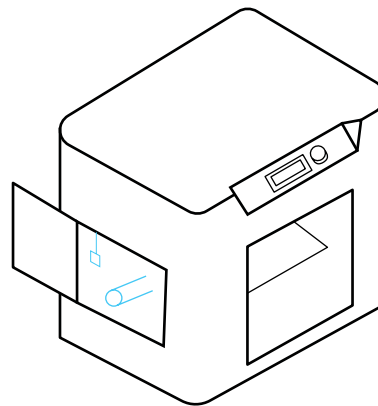

4.

4. If you load the material for the first time, skip this step. If you change the filament, remove the old material from the tube through the filament sensor inside the chamber and remove the spool from the roller.

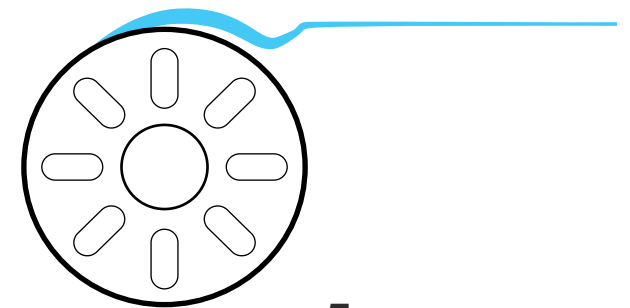

5.

5. Prepare the new filament spool—unravel **about 40 cm of material** and make sure that the material is clean. Then straighten **around 5 cm** of the filament that you want to load to allow its smooth insertion into the head. Uneven ends must be cut using a pair of pliers, which you can find in the toolbox.

Installation / Change of filament

PROCEDURE FOR CHANGING A FILAMENT

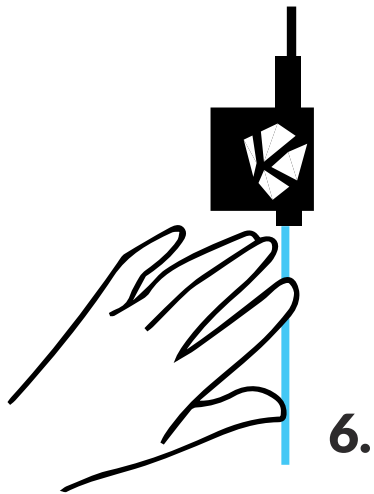

6. Load the material into the filament sensor located inside the filament compartment. Continue to load about 40 cm of it until you clearly feel resistance.

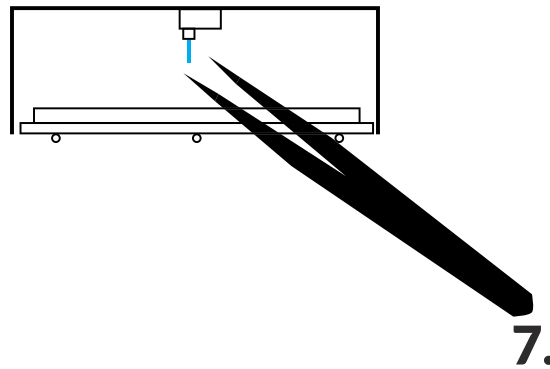

7. Choose the *Insert filament* option from the menu repeatedly while at the same time pushing the filament at the opening of the sensor. The extruder should draw the material, resulting in a mild increase in the filament's downforce. Choose the option *Insert filament* until the material comes out of the print head. Remove excess filament with tweezers.

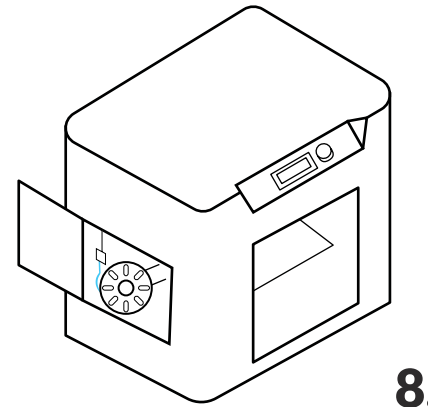

8. Place the roll of material on the roller and close the door of the filament compartment.

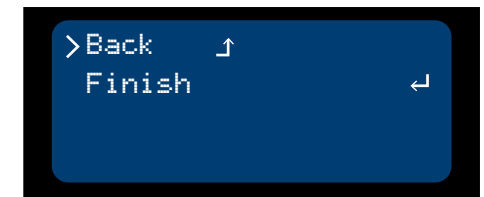

9. From the menu, select *Exit*. Following this procedure, the printer is ready to print using the new filament.

Printing

FIRST PRINT

Printing with 3DKreator is easy.

Follow these guidelines to create three-dimensional models:

- 1.** Perform calibration of the platform with a procedure which can be found in this manual (page 16)
- 2.** Instal material in your printer (page 18)
- 3.** Insert the SD card into the reader located at the lower right corner of the device.
- 4.** From the main menu select *Print*.
- 5.** From the menu, choose the type of material used, followed by the file that you want to print.
- 6.** The printer will warm the head and print platform to the setpoint temperatures, after which it will begin to print.
- 7.** After the printing process, wait until print head and working platform cool down - the background color will change to blue. To remove the model from the platform use spatula, which you will find in starter pack added to your printer. Remember to wear gloves and protective glasses.

Additional information



Each time you print, clean the table with the remains of the filament and other dirt. It has a big impact on the proper bonding of layers of the material in the initial stage of printing. Use spatula and dry cloth.



Filament should be stored according to manufacturers guidelines.

It must be clean and dry place. Contact with moisture and dirt may negatively affect its properties and result in problems with the device. Malfunctions caused by the use of low-quality filament are not covered by the warranty.



The success of print largely depends on its base. It is worth watching the process of applying few initial layers. If they are fully set on the platform, we can be confident that the further printing process will be conducted properly.



Do not heat the print head when fans are removed (ex. during maintenance), it may cause a damage of the printer.

Technical support

For more information on operating the device please visit our website:

www.3dkreator.com

In case of problems and ambiguities related to the use of Kreator Motion printer, please contact us at support@3dkreator.com, please quote the serial number of the device or use the form available on the website

www.3dkreator.com



3DKreator